

**UNIVERSITY OF EL SALVADOR
SCHOOL OF ARTS AND SCIENCES
DEPARTMENT OF FOREIGN LANGUAGES**



TOPIC

Contribuciones y beneficios que se reflejan en las traducciones de traductores principiantes con el uso adecuado de herramientas de traducción (Cat Tools)

Contributions and benefits reflected in the translation of beginner translators through the proper use of translation tools (Cat Tools)

PRESENTED BY:

CÉSAR ALBERTO GARCÍA COLINDRES
ROSIBEL ESMERALDA LÓPEZ PÉREZ
MILTON ALEXANDER NIETO TORRES
NUBIA CAROLINA SOLANO DE CALLEJAS

CARNET

GC14084
LP13012
NT13002
SH17009

INFORME FINAL DE CURSO DE ESPECIALIZACIÓN

CURSO DE ESPECIALIZACIÓN: FUNDAMENTOS DE LA TRADUCCIÓN

IN ORDER TO OBTAIN THE DEGREE OF:

BACHELOR OF ARTS IN MODERN LANGUAGES WITH A MAJOR IN FRENCH AND ENGLISH OR BACHELOR OF ARTS IN ENGLISH WITH A MAJOR IN LANGUAGE TEACHING

MsT. NOHEMY ELIZABETH REYES LÓPEZ.

SPECIALIZATION PROFESSOR

LIC. MIGUEL ÁNGEL CARRANZA CAMPOS, MsE.

GENERAL COORDINATOR OF THE GRADUATION PROCESS

**CIUDAD UNIVERSITARIA, DR. FABIO CASTILLO FIGUEROA,
SAN SALVADOR, EL SALVADOR, CENTROAMÉRICA, ABRIL DEL 2024**

AUTHORITIES OF THE UNIVERSITY OF EL SALVADOR

RECTOR

MAESTRO. JUAN ROSA QUINTANILLA

VICE-RECTOR

DOCTORA. EVELYN BEATRIZ FARFAN MATA

ADMINISTRATIVE VICE-RECTOR

MAESTRO. ROGER ARMANDO ARIAS ALVARADO

GENERAL SECRETARY

LICENCIADO. PEDRO ROSALIO ESCOBAR CASTANEDA

UES GENERAL ATTORNEY

LICENCIADO. CARLOS AMILCAR SERRANO RIVERA

AUTHORITIES OF THE SCHOOL OF ARTS AND SCIENCES

DEAN

MAESTRO. JULIO CÉSAR GRANDE RIVERA

VICE DEAN

MAESTRA. MARIA BLAS CRUZ JURADO

GENERAL SECRETARY

MAESTRA. NATIVIDAD DE LAS MERCEDES TESHÉ PADILLA

AUTHORITIES OF THE DEPARTMENT OF FOREIGN LANGUAGES

HEAD OF THE DEPARTMENT OF FOREIGN LANGUAGES

MAESTRO. JOSÉ ISRAEL OLIVA

GENERAL COORDINATOR OF THE GRADUATION PROCESS

LICENCIADO. MIGUEL ÁNGEL CARRANZA CAMPOS

SPECIALIZATION PROFESSOR

LIC. NOHEMY ELIZABETH REYES LÓPEZ.

INDEX

	PAGES
1 ABSTRACT.....	4
1.2 INTRODUCTION.....	5
1.3 Argumentative Text	7
2. TRANSLATION PROCESS	
2.1 Concept of the Translation Process	10
2.2 Mind Map of the Steps in the Translation Process	11
2.3 Explanation of the Steps in the Translation Process	12
2.4 Translation Techniques, Explanation and Examples	13
3 TRANSLATIONS	
Definition of Translation	16
3.1 Original and Translated version of the images: Plants, Digestive System, Comics	17
3.2 How Engines work	23
3.3 Operation Manual MP5 Player	25
3.4 Birth Certificates	48
3.5 Marriage Certificates	50
3.6 University Transcripts	52
3.7 University/High School Diplomas	60
3.8 Medical Certificate	62
4 CONCLUSIONS	64
5 RECOMMENDATIONS	66
6 REFERENCES	67

1 ABSTRACT

We found out that this specialization in Translation carry out how translator can apply different way to produce a new text translation using tools like Cat Tools this contributes especially for beginner translators' translation; the purpose of this investigation is mostly to reduce time's handing costumer translations in order to maximize your experience. for example when we translate a birth certificate in the past with no internet connection this time to traduce this document can be handing to the client in 3 or 4 nowadays using cat Tools is the fast way to get Satisfactory results of translated texts and image editing of a document can be attained through the study of accurate translation techniques and the practice of Cat tools This report presents how the six-month course of Specialization in Translation Fundamentals was developed; through this course, students were able to understand and practice the fundamentals of translation techniques and the usage of Cat Tools for translation. As conclusion, we realized that using those tools, students learned how to translate documents such as diplomas, birth certificates, and records, to provide the translation of the source language to the target language. This report encompasses the translation works completed throughout the semester using translation techniques and Computer-Assisted Translation tools. Cat Tools play a significant role in modern translations as they facilitate time management while translating, image editing, or group translating.

Keywords: translation, translation techniques, Cat Tools, source language, target language.

1.2 INTRODUCTION

The present work is to receive the degree of Bachelor of Arts in English with a Major in Language Teaching or Bachelor of Arts in Modern Languages with a Major in French and English from the University of El Salvador. It is a work that tries to incorporate the ideas, theory, practice, and all the effort developed through the four modules of the Specialization Course: Fundamentals of Translation. In these four modules, we have been knowledgeable and participated in each of the topics taught such as “the fundamentals and techniques of translation, the translation process, the use of technological tools for translation (CAT Tools), and translation practices”, in which both the Bachelor in English: Pedagogy Option and the Bachelor in Modern Languages: English and French Option, have been active participants in order to successfully complete each of the different modules required for this specialization.

This document contains several points to be emphasized such as the argumentative text which defines in one page the importance of translation today, the proper use of technological tools for creation, editing, formatting, and more, which help to reduce the translation work time of a document. Continuing with the description and process of document translation shown in a mind map as a reference of the process to follow, it is a way that as a group we see the translation process in a simplified way, to obtain an excellent quality translation. Each of the steps will be defined and explained in a clear, simple, and precise way and thus understand the importance and support for translators to obtain a good result in the translations.

In addition, the document includes a brief definition of the term "translation" based on the experience during the course, and what other sources suggest to include in the translation process.

Also, original versions and translations of some of the works elaborated during the course are included to show the knowledge that the team has been including during the specialization course, and how the different techniques have been applied to these translation works that help the students of the course to enrich the knowledge, and everything that a real translation handles, enrolls, and develops.

Finally, the document concludes with a list of recommendations to future students who will take the specialization course considering those things that future graduates have to do, and should avoid during the development of the course. This will help future students to take into consideration certain points that bachelor students have experimented with through the whole process of the specialization course and be ready for what they are going to encounter in this process.

1.3 ARGUMENTATIVE TEXT

Cat Tools have become an ally of modern translators as they help speed up the process of translations and offer different contributions and benefits such as optimizing time while performing translations and access to predetermined glossaries related to specific subjects, for instance. Although experienced translators do not rely primarily on Cat Tools, beginner translators can find a relevant boost to their proficiency and efficiency when translating through the adequate use of Computer Assisted Translation Tools.

A study held in 2014 by the Arab World English Journal (Alotaibi, Pp. 65-74), shows that introducing and integrating technology into translation curricula proved to be successful in terms of enhancing students' skills and maximizing their productivity in translation. Translation students became aware of the significant role of technology, also became able to convert printed text to electronic using scanning & OCR, able to identify different types of corpora; in addition to that, these students became able to choose the Cat Tools according to their needs, and learned how Translation Memories work among many other benefits and contributions that Cat Tools provided to these beginner translators.

Computer Assisted Memory Tools are very friendly to beginner translators as the memories and glossaries speed up the process mostly for technical translations. The Routledge Handbook of Translation and Memory (Deane-Cox & Spiessens, 2022) suggests that Cat Tools are most successfully used for technical translations doing an excellent job; nevertheless, it poses the opportunity to test Cat Tools for literary translation, where the Computer Assisted Memory Tools are deemed to be proficient enough. Thus, these tools pose a great contribution to time management for any genre of text the translator wishes to translate.

Cat Tools are not only useful for the translation of text-based documents, but they are also useful for the translation of documents that contain images or graphics. Although, according to Kornaki (2018), there are few Cat Tools that provide this service, throughout this 5-year span, tools such as MateCat, for example, have proved to work well enough with simple images that require minimal graphic editing. These kinds of computer-assisted tools can easily translate a document with any sort of format or design keeping the same or a very similar design to the original. Any translator knows that formatting and image edition do take a significant amount of time when working with this type of translation as they usually require other types of tools and knowledge of some sort about graphic design. Beginner translators must be already knowledgeable of the translation techniques in order to take full advantage of the perks that Cat Tools present.

One of the many benefits of using Cat Tools is the improved consistency of translations while delivering shorter time; for example, a large volume of translation at a quicker turnaround time performing greater quality assurance capability. This feature not only facilitates the job for an individual but also facilitates the job for translation teams.

Translation is quite complex, as it involves several crucial parts such as source language, target language, and transfer of meaning; while learning the process, using some assistance is vastly helpful. As a beginner translator, this job might not seem simple while trying to transfer the meaning from the text written in the source language accurately. For this reason, translation courses should definitely include Cat Tools as part of the curricula. An article posted on *Theory and Practice in Language Studies* (2022) shows that the use of the functional capabilities of Cat systems in the implementation of written translation has a positive effect on forming contemporary professional and personal competencies of students, as well as on improving the quality of training of future translators. It opens up opportunities to work with contemporary

content and text formats, hence expanding students' vision of the modern market in translation services and how computer technologies relate with linguistics. Teaching the use of Cat Tools for beginner translators improves their general computer literacy and their participation in real translation projects.

2. TRANSLATION PROCESS

2.1 Concept of the Translation Process.

According to Crystal (1991) translation is the process through which “the meaning and expression in one language (source) is tuned with the meaning of another (target) whether the medium is spoken, written or signed” (p. 346). Thus the translation process consists in language processing and text production of two different languages; the former originating from the source language (SL) into the latter, the target language (TL). The translation process does not only include the literal processing and production from one language to another but also includes the use of techniques that allow fidelity of the meaning from the original source to the other. Just as Edith Grossman said, “To recreate significance for a new set of readers, translators must make the effort to enter the mind of the first author through the gateway of the text – to see the world through another person’s eyes and translate the linguistic perception of that world into another language.”

Also, under the scope of Steines’s point of view, the translation process is basically understanding the communication in which a transfer of information occurs from one language to another; nevertheless, this information transfer involves a great amount of learning about the way of life of the person, situation or thing that is providing such information. Hence, the translation process is an intricate process that involves deep cultural knowledge of the places where both the languages (SL and TL) are spoken, knowledge of the type of text that is being translated to communicate the meaning in a wholesome manner, and the accurate use and knowledge of grammar either written or spoken in both languages.

2.2 The Translation Process Steps.

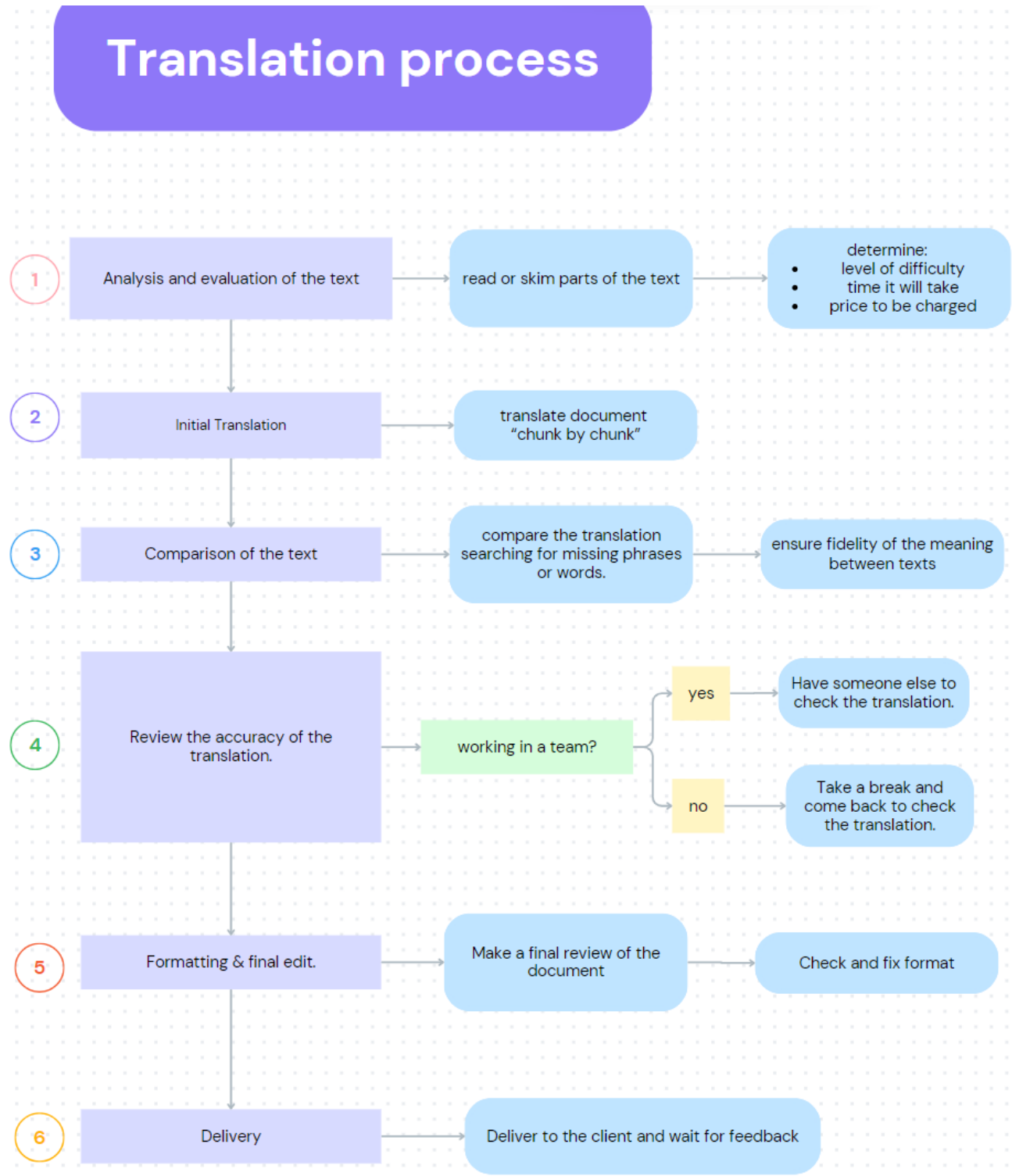

2.3 Explanation of the Translation Process.

- I-** In the first step, the analysis and evaluation of the text is performed by getting a general idea of the text through reading or skimming parts of the text. This quick scan will also help determine the level of difficulty, the time it will take to translate and how much the client will be charged.

- II-** Then, in the second step, Initial translation, the original text is separated into chunks and translated.

- III-** The third step is a comparison of the text, in which both texts (Source language and target language texts) are compared to check for missing phrases or words ensuring the fidelity of the translation.

- IV-** As the fourth step, the review of the accuracy of the translation is done. If working with other translators, a different person should check the translation. If working by oneself, one must take a break and check the translation afterward.

- V-** Step number five consists of formatting and final edit. The translator does a final checking and editing and ensures the format is adequate.

- VI-** Lastly, in step number six, the delivery is performed through the client's requested means.

2.4 Six Translation techniques, explanation and examples.

Translation Techniques

1. Borrowing: Is a technique that does not seem to be a “translation” since it uses words or expressions from the source language. As its name suggests, it borrows the word from the original text and inserts it into the target language, normally without any modification, the translator uses this technique.

1. There is no equivalent in the target language.
2. There is an equivalent, but the borrowed word conveys the meaning better than the target language word.
3. The translator wants to preserve and give the sense or feel of the target language.

Examples:

Internet, pizza, ballet, Sushi.

2. Calque Technique: Is a translation method by which a phrase is translated literally from the source to the target language. This word-for-word translation constructs a new term in the target language, such as the Italian term “express,” which comes from Italian worth noting that Calques can spread widely in the target locale if they are absorbed and accepted by natives like “breakfast” that comes from the English term “*fastenbryce*.” However, Calques can likely fail in the target language if the translator doesn’t utilize them cautiously.

Example:

-In order to - *en orden a*

-Super man- *super hombre*

3. Transposition: Owing to the contrasts in grammatical structures between different languages, the transposition technique comes into play. It's when the translator changes parts of the text order (sentence structure) while retaining the same meaning as the original text, such as the English sentence "He likes dancing" that turns out to be "*Er tanzt gern*" in German. Transposition is particularly the favorite technique for English and Spanish translators since both languages are dramatically different grammatically. English verbs are likely to come at the beginning of the sentence, while the Spanish verb comes at the end.

Example:

-Of interest to students.

4. Modulation: Is all about adjusting the point of view of the source language. Without changing the purpose of the text, the translator uses another phrase in the target text to convey the same meaning as the original text. It involves semantic and perspective change while preserving the intent of the source language's text. The translated text should give a sense of nativeness, such as the French phrase "dernier stage" -which means literally "Last Stage"- that turns out to be "top floor" in English.

Example:

-Don't be afraid - *Ten valor*.

5. Adaptation: It occurs when something specific to one language culture is expressed in a totally different way that is familiar or appropriate to another language culture. It is a shift in the cultural environment. Should *pincho* (a Spanish restaurant menu dish) be translated as *kebab* in English? It involves changing the cultural reference when a situation in the source culture does not exist in the target culture (for example France has Belgian jokes and England has Iris Jokes).

Example:

-Alissa traveled 10,00 miles - *Alissa viajó 16,093 kilómetros*.

6. Compensation: Is a technique utilized when something cannot be translated into another language, whether it is a grammatical concept in the source language or a cultural construct that has no equivalent in the target language. For example, some languages distinguish formality when addressing another person (e.g., *tu* and *vous* in French, as well as similar examples in German, Slovak, and other languages), in contrast to English, which only recognizes one "you," and instead expresses formality degrees in other ways.

Example:

-Thou are a courageous knight. - Usted es un caballero valiente.

3. TRANSLATIONS.

Definition of translation.

Throughout these four modules of the specialization in translation, we were able to realize that translation is more than the simple action of transferring the meaning of a word from one language to another, it is an extensive and very meticulous work since it implies demonstrating our grammatical knowledge, analyzing, investigating, applying techniques and procedures so that the translation is effective and can fulfill its purpose, which is that the reader can perfectly understand the message that is being transmitted, that is why the translator must keep in mind the steps to follow to achieve an effective translation.

The translation must be based on the client's needs, as students of this specialization course in translation we have learned what translation means, and how it can be better developed with the support of different techniques, procedures, methods and of course knowing how to use different technological tools such as Cat Tools, which will make our work much faster and more effective.

3.1 Treated images

- Plants: Original

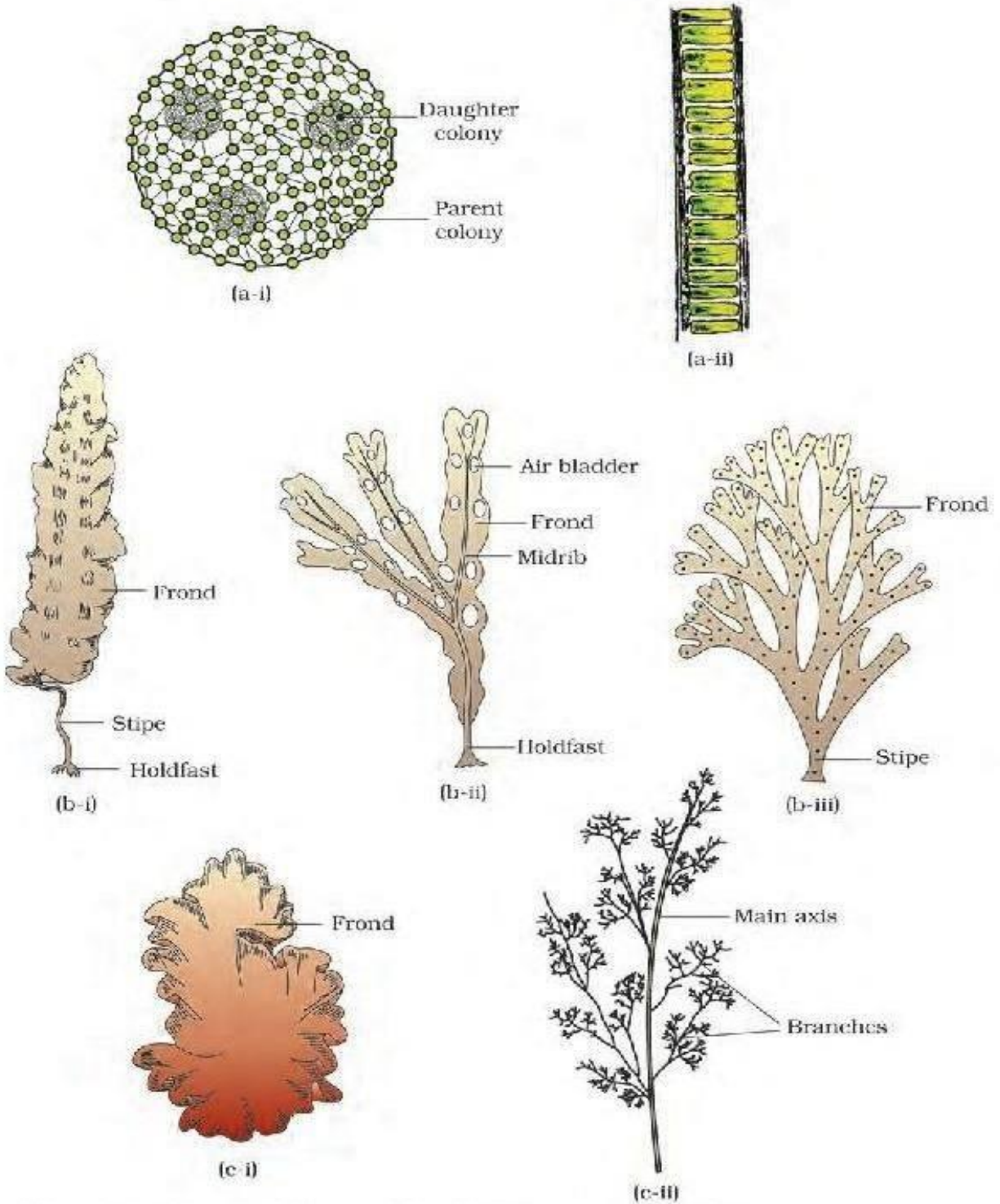
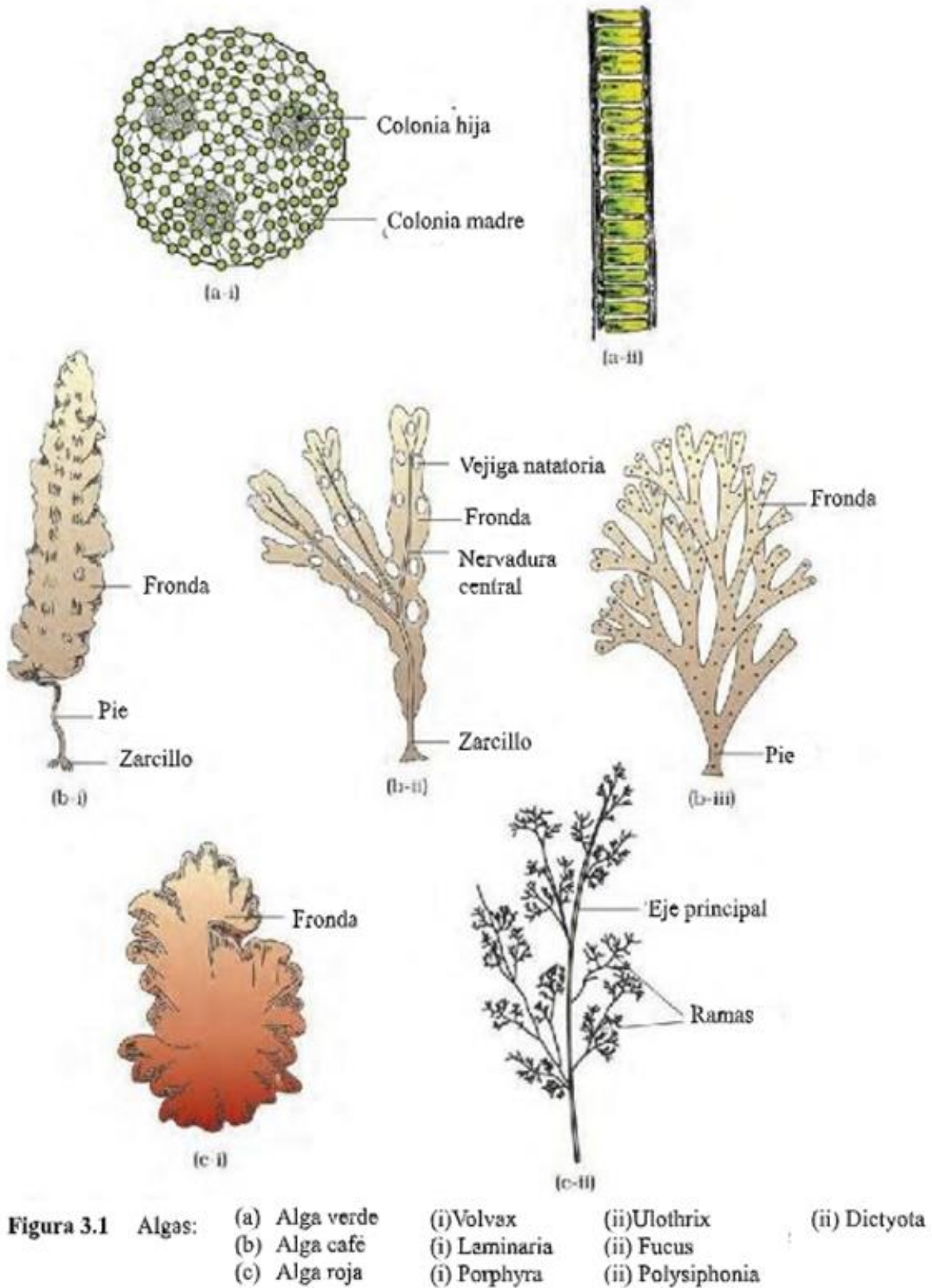
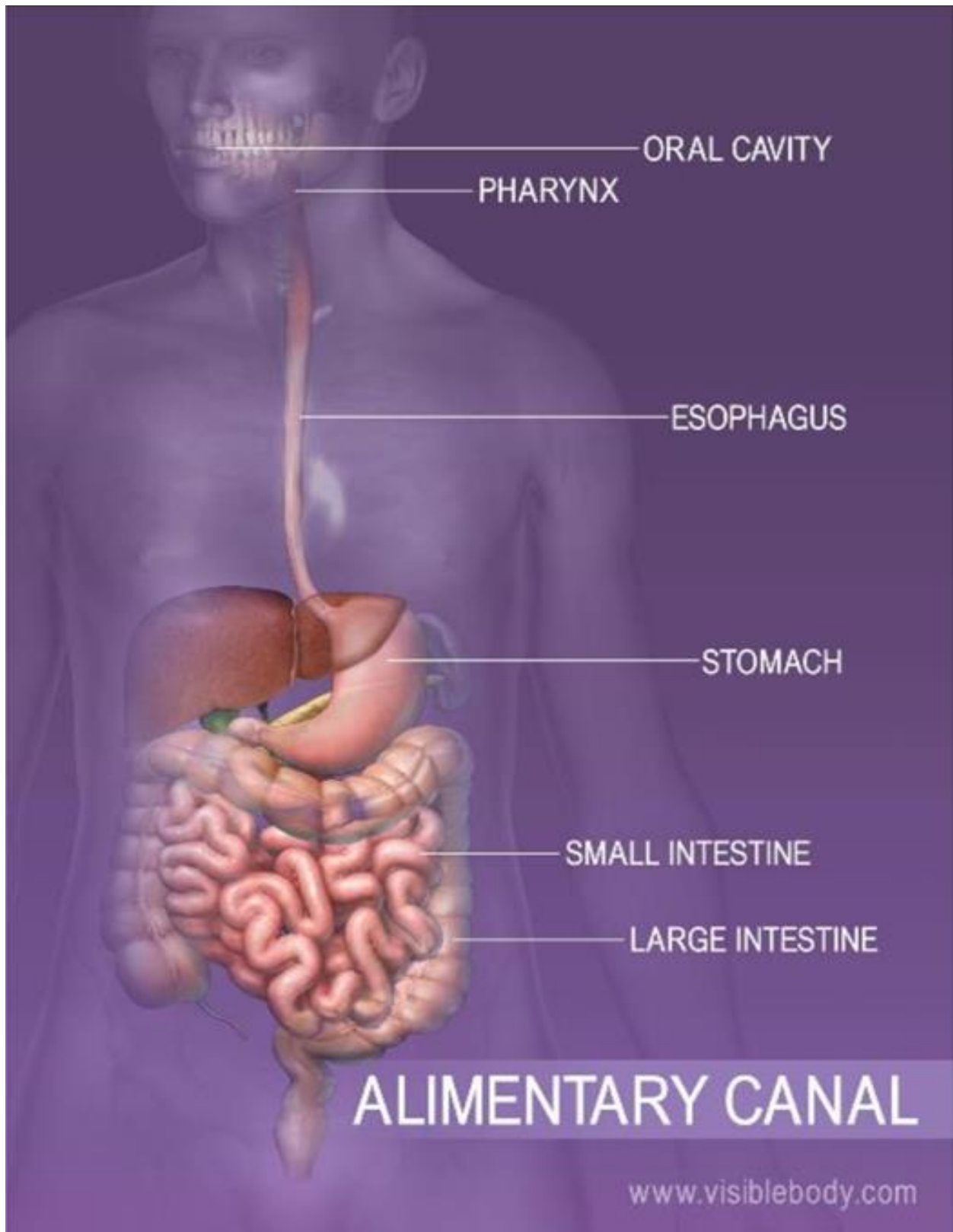

Figure 3.1 Algae : (a) Green algae (i) *Volvox* (ii) *Ulothrix*
 (b) Brown algae (i) *Laminaria* (ii) *Fucus* (iii) *Dictyota*
 (c) Red algae (i) *Porphyra* (ii) *Polysiphonia*

Translation



- Digestive system: Original



Translation



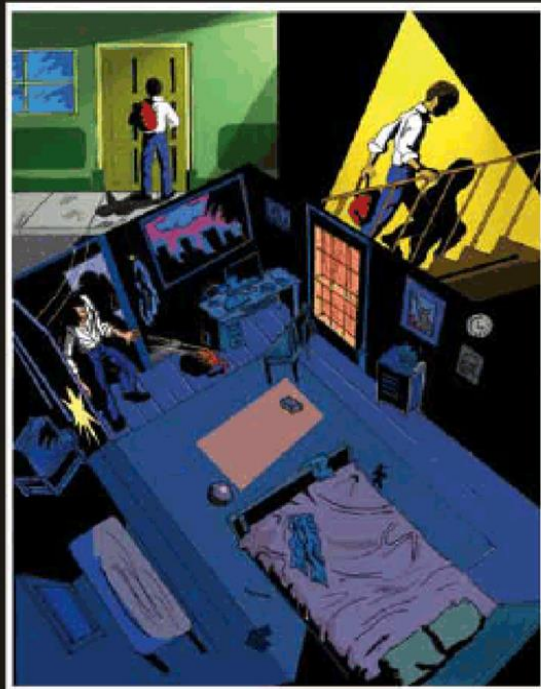

AS USUAL, MR. LOIS GOT AN F AGAIN. IF HE GOES ON LIKE THIS, HE WON'T GET FAR.



AHHH - - ENGLISH IS NOT USEFUL FOR ANYTHING.

IT DOESN'T MATTER.



THIS APARTMENT IS VERY SMALL.



IF I CONTINUE LIKE THIS, I'LL HAVE TO SAVE MONEY FOR A YEAR TO RENT A BIGGER APARTMENT.

Translation



3.2 How engines work: Original



Parts of an Engine

An internal combustion engine uses motion to repeat the cycle. While it relies on an explosion to make everything go, the basic idea behind its rotation is similar to that of a steam engine or a water wheel. Some of the key parts are:

- **Engine Block** – This is the foundation for your engine. It's usually made of aluminum alloy or iron. The engine block is the home of your cylinders. All the motion that causes the combustion reaction takes place inside the cylinders. Most cars today feature a 4-cylinder engine, but many are also built with six or eight cylinders for more power.
- **Valves** – Each valve is crucial to moving air through your engine. There's both intake and outtake valves. Usually there's one of each for every cylinder. The valve train is the system that controls when air is brought in and when it's pushed out your exhaust at the end of the cycle.
- **Pistons** – Every one of your cylinders has a piston moving up and down inside it. This solid metal part is at the center of the combustion cycle.
- **Crankshaft** – The crankshaft is attached to the base of each piston by a connecting rod. The motion of the crankshaft is what's used to control when the pistons go up and when they come down.



Partes del motor

Un motor de combustión interna utiliza el movimiento para repetir el ciclo. Si bien se basa en una explosión para hacer que todo funcione, la idea básica detrás de su rotación es similar a la de una máquina de vapor o una rueda de agua. Algunas de las partes más importantes son:

- **Bloque del motor:** Esta es la base del motor. Por lo general, está hecho de una aleación de aluminio o hierro. El núcleo de los cilindros se albergan el bloque del motor. Todo el movimiento que genera la reacción de combustión tiene lugar dentro de los cilindros. En la actualidad la mayoría de los vehículos cuentan con un motor de 4 cilindros, sin embargo, muchos también están contruidos con seis u ocho cilindros para obtener más potencia.
- **Válvulas:** cada una de las válvulas es crucial para transportar el aire a través del motor. Existen válvulas de entrada y de salida. Por lo general, suele haber una válvula de entrada y una de salida por cada cilindro. El mecanismo de válvulas es el sistema que controla cuándo entra el aire y cuándo sale por el escape al final del ciclo.
- **Pistones:** En el interior de cada cilindro, se encuentra un pistón, el cual se mueve de arriba hacia abajo. Esta pieza metálica sólida está en el centro del ciclo de combustión.
- **Cigüeñal:** el cigüeñal está unido a la base de cada pistón por una biela. El movimiento del cigüeñal permite controlar el movimiento de los pistones cuando suben y bajan.

OPERATION MANUAL

**CAR MP5 PLAYER WITH
7 INCH HD DISPLAY PANEL
FM RADIO RECEIVER
BT
MIRRORLINK**

Before installation

Thank you very much for purchasing and using our products, when you receive the product, please do not take the product directly to the car for installation, because the product is in the after a long journey, it may affect the product. Please try the machine before installing.

Test method: Take the machine to the battery of the car and test it. This car stereo applies to a power supply voltage at 12V DC, Connect the red and yellow wires of the power cord of the machine together and connect it to the positive pole of the battery. The black wire of the power cord is connected to the negative pole of the battery. Wait for 10 seconds after connecting, press each button of the machine to see if the machine can boot normally. If it can be turned on, it means there is no problem, you can install it. If the test machine can not start normally, please again Confirm that you follow the steps of our test method in strict accordance with the operation. If the problem is still not solved, please contact our work in time.

Thank you for your cooperation.

BASIC PARAMETERS

Operating Voltage	DC12V
Maximum Current	15A
Operating Temperature	-10~+60°C
Screen Size	7 Inch
Screen Resolution	800*480
System	Windows CE
Output Power	60W x 4
BT Function	Ver:4.0 Built-in microphone
Phone Link	Android/Iphone (Some high version phones do not support)
Support Video Format	RM/RMVB/FLV/3GP/MPEG/DIVX/DAT/VOB/AVI/MP4
Support Audio Format	MP3/WMA/WAV/FLAC/APE/OGG/
Support Picture Format	JPG
Button Light	Colorful light automatic / Monochrome light optional
Radio Frequency	FM 87.5~108MHz
Support media devices	USB 2.0/TF card
AUX Input	Front panel 3.5mm interface
Reverse Function	Support (camera option)
Remote Control	Infrared remote control
Language Selection	English/Chinese/Spain/Portugal/French/Italy/Russia/German/Turkey/Czech/Polish/Thai
Steering Wheel Controls	Support

UNIT INSTALLATION SIZE

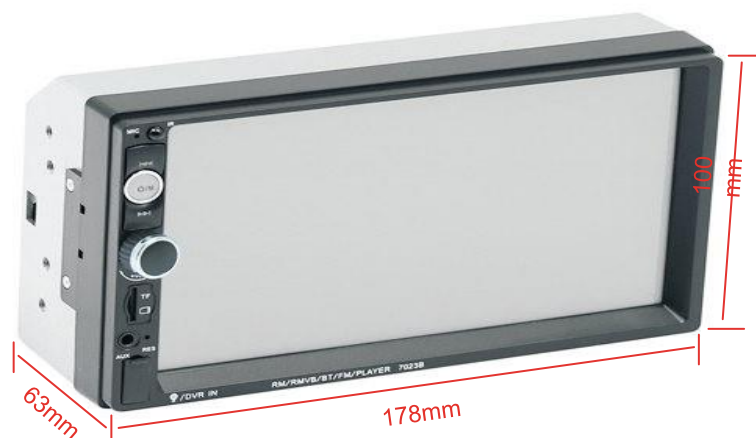

PANEL COMPONENT DESCRIPTION

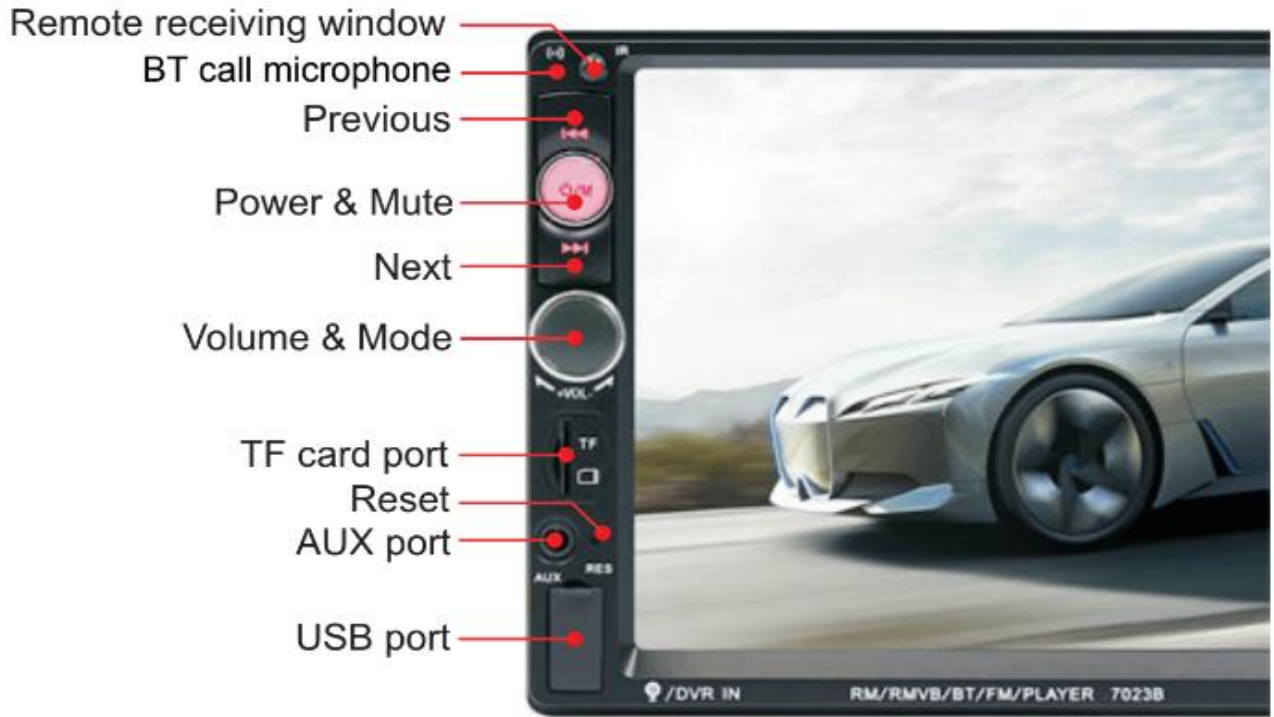

REAR INTERFACE DESCRIPTION

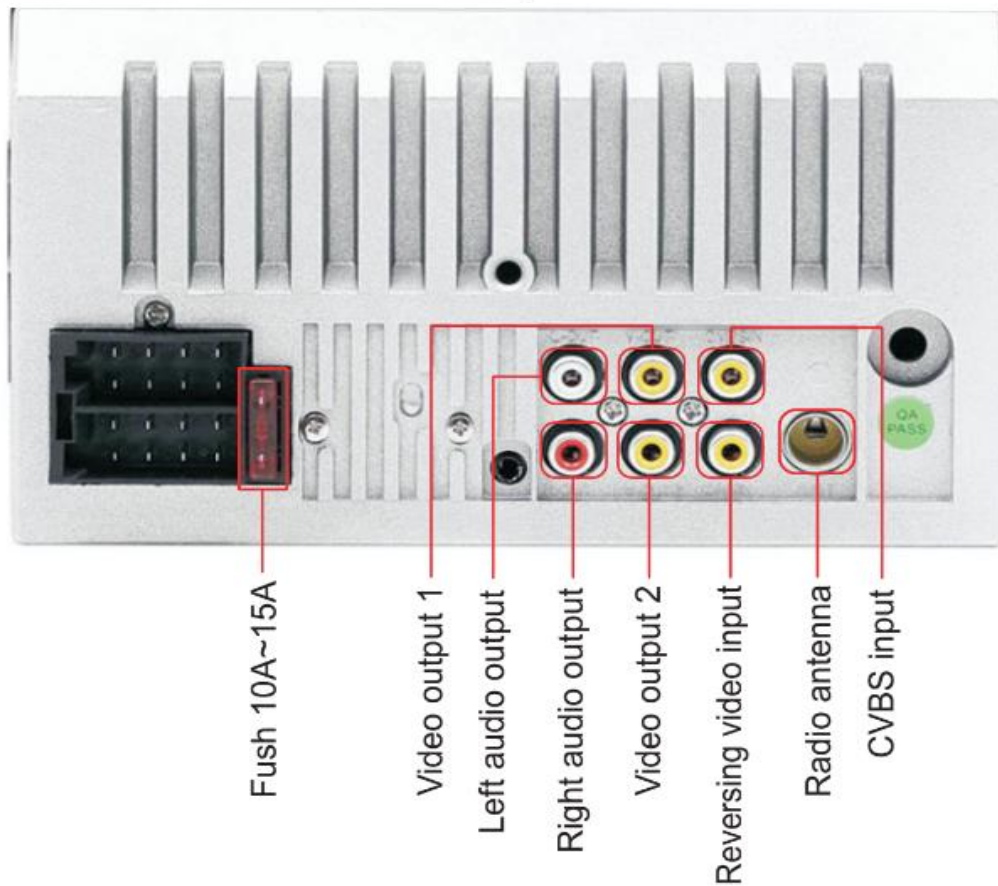

PANEL COMPONENT DESCRIPTION

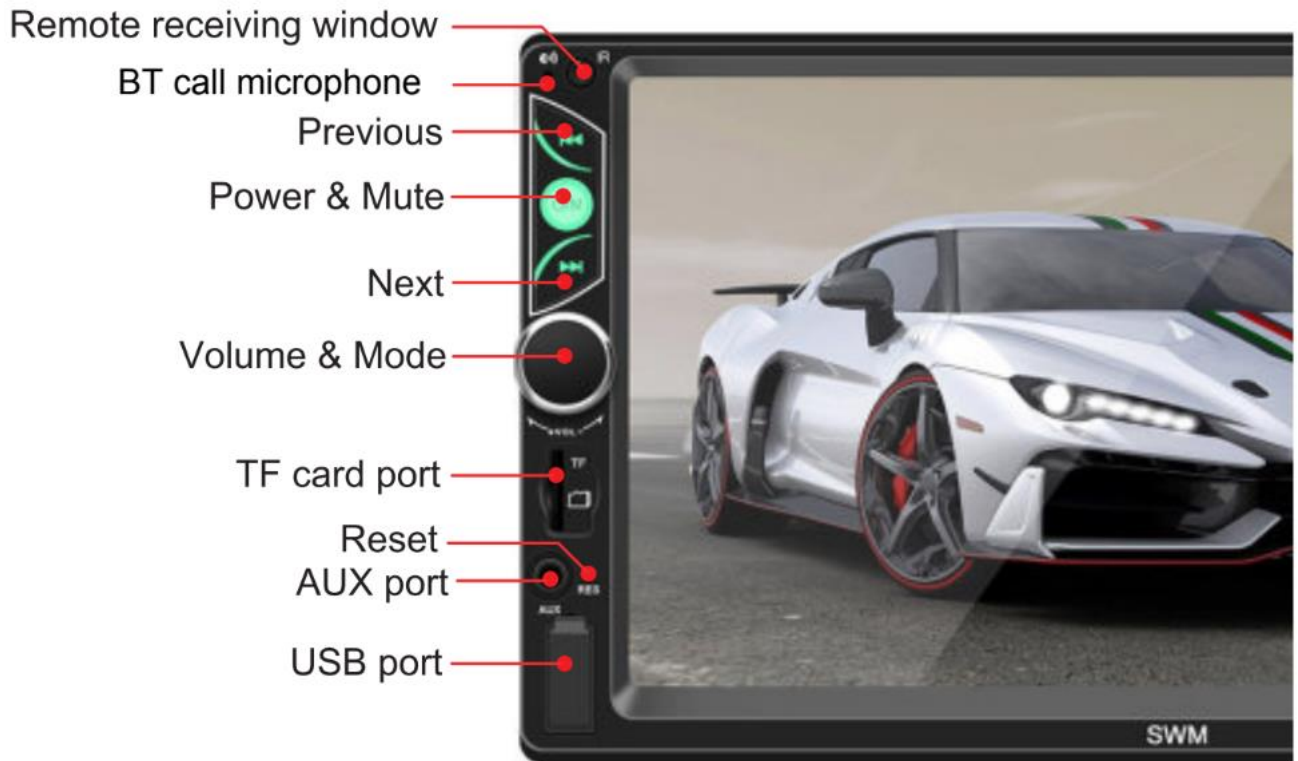

REAR INTERFACE DESCRIPTION

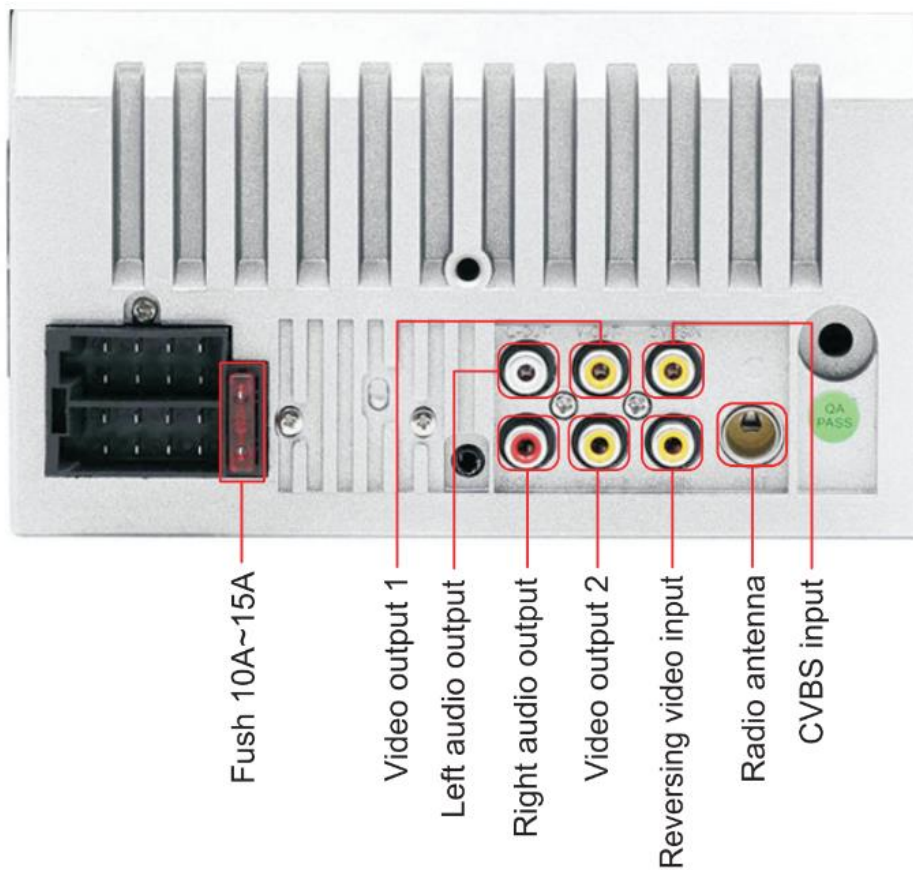

REAR INTERFACE DESCRIPTION

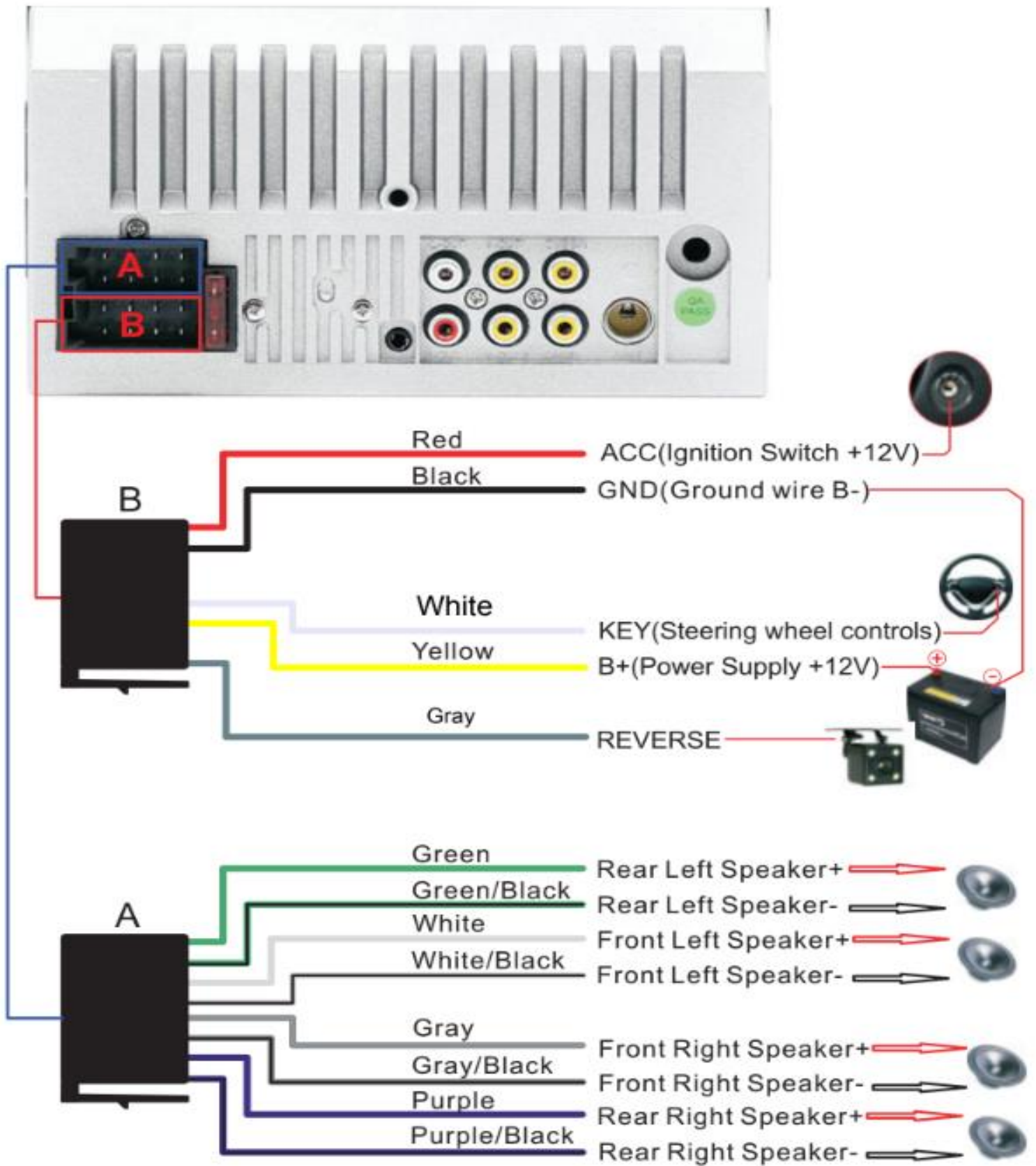

PHONE LINK FOR IPHONE

* For iOS, X series and higher versions of mobile phones do not support mobile "phone link" with this machine.

1. Connect the machine and mobile phone with the original data cable.
2. When the phone pops up a dialog box: Trust This Computer? Select Trust to enter the interconnect mode.



STEERING WHEEL CONTROLS

1. Connect the positive pole of the original steering wheel to the KEY(White) line of the machine plug.
2. Connect the negative pole of the original car steering wheel button wire to the GND(Black) wire of the machine plug.
3. In the "settings" interface, find "Steer" and enter.
4. Enter the steer and press the button to learn. After the learning is successful, click the "OK" button on the page. After saving, you can use the buttons on the original steering wheel to control the machine.

Learning method: press and hold a button on the steering wheel of the original car without letting go, find the button icon corresponding to the function of the button on the steering wheel of the machine. Click this icon to change the color, indicating that the button has been successfully learned, according to the same The way you can learn other buttons. After all the keys have been learned, click the "OK" button on the page to save the settings. If you need to relearn, please click the "RESET" button on the page and then re-learn.

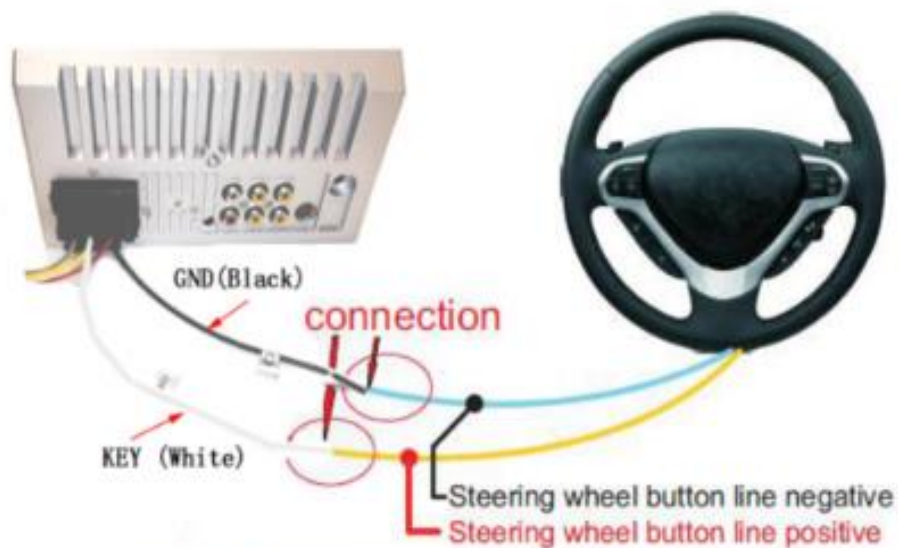

COMMON PROBLEMS AND SIMPLE TROUBLESHOOTING

1> Unable to boot normally

--- Reason for not booting

1. "Yellow" "Red" "Black" this 3 lines only connected 2 line of them, so it will not start, it should be that the yellow line is connected to the positive pole, red line to the key control line, black to the negative pole, less connection or wrong connection does not boot.
2. The original car line and unit wiring can not be connected to the color, the color of the original car line is not standard, if you connect like that it can not only be turned on but also may burn.
3. The original car plug can't be plugged directly into the new unit, even if it just plugs in, it can't be used, otherwise it won't be turned on or burned.
4. The 3 wires are connected right, but it does not boot. Check if the fuse on the yellow line is broken. If there is no problem with the fuse, twist the yellow and red wires together. Turn on the key and press the unit's power button to see if it can be turned on.
5. Every time you change the fuse, it burns. Please don't change it again. The reason is that when you first connect the positive and negative poles, the protection circuit of the unit is short-circuited. The unit can be repaired under the guidance of our master. No basis can only be returned to the after-sales or new unit. If these are no problem, or also don't boot, please make the final step to confirm, find a 12V battery or 12V power supply "yellow" and "red" twist together with the positive, black to the negative pole, press the button check if it can boot or no, if you can boot, it showed that the original car line is not right connect, or there is a problem with the car line. If it can't be boot, the unit is broken. Does not boot unit, check the line carefully, do not blindly suspect the unit problem.

2> Automatic shut-down

--- Automatic shutdown usually has these following conditions

1. The cable error connect: If the blue cable (automatic antenna power supply) is connected to the power cable of the unit, an automatic shutdown will occur. Please follow the correct wiring method to solve the problem.
2. The voltage is unstable: please find a 12V-5A which one is the power supply and re-tested to see if it will automatically shut down or no. If it does not automatically shut down after the test, please replace the power supply. If it will automatically shut down, it is problem with the unit.

3> Having noise

--- The general situation of noise is caused by two reasons

1. The original speaker power is too small. When the volume of the unit is turned up, there will be noise.

Solution: When replacing the speaker or listening to the song, the volume should not be too large.

2. The speaker cable is grounded.

Solution: Take the iron speaker cable. Directly connected to the speaker cable of the unit.

4> Settings cannot be saved (no memory)

--- There is no memory function, there is only 2 points in memory

1. The yellow line and the red line are connected together (separate yellow to positive, red to key control).
2. Yellow and red are reversed (just change position).

5> Car audio with BT but it can't work

--- Check the phone to see if you can search for the unit code or no.

Operation steps: turn on the unit, use the phone Bluetooth search, search for CAR-MP5, then click the connection, after connecting, you can answer the phone or BT to play the song

PIN Code: 0000 .

6> The product smoke has proved that the internal circuit has been burned and change the insurance FUSE can not solve the problem

--- In this case, the unit needs to be repaired.

7> How to adjust the sound, where is the equalizer set, the sound can not be adjusted

--- Adjust the sound: please turn the volume to adjust.

--- Equalizer settings: In general, press the volume knob to display the equalizer SEL, and rotate the volume button to adjust each sound effect.

--- The sound cannot be adjusted: 1. Please reset the unit or unplug the power cord and plug it in. 2. The Volume knob is broken, and the knob can be replaced.

8> Support no image of reversing camera

--- Generally two situations

1. Connect the wrong line or less wiring. Camera connection method:

- a> The first step is to find accessories (accessory: one camera + one power cord + one video cable).
- b> The second step is to find the port of the wiring. First find the reversing control line on the power line of the unit. The control line is a pink line or brown line, connect this line to the positive pole of 12V and the screen will turn blue. Find the back of the unit the CAME video input interface, find the positive and negative of the backup light. The third step is to connect: there are two sockets on the camera, the red socket is connected to the power cable, the yellow is inserted into the video cable, the red wire of the power cable and the wire of the video cable are screwed together on the positive pole of the reverse lamp, and the black wire of the power cable is not used, connected, the other end of the video cable is connected to the

CAME video input interface on the back of the unit. The red line coming out of the video line is connected to the reversing control line of the power line.

2. The camera is broken. If the lamp that is properly wired to the camera is not lit, it will be broken and replaced with a new one.

10> USB flash disk can not be played, the card with the map can not be recognized, the card slot does not enter the card, the map card folder has no content?

--- USB flash disk can not play:

Format the USB flash disk, and the file system is selected as: FAT32, re-download on or two songs and try again. If it still doesn't work, please replace the USB flash drive.

--- The map card cannot be recognized(Only for GPS models):

Insert the card into the computer to format, re-download the map or change the memory card to download the map software.

--- The card slot does not enter the card:

Check whether the memory card is inserted, the plug is broken.

--- There is no content in the map card folder(Only for GPS models):

Insert the card into the computer to view it. If there is no content, you need to download it again.

11> FM does not receive the program

--- Can not receive the station check the 2 points

1. The antenna plug is not fully inserted, the antenna is disconnect or the line is disconnect.
2. Search channel, hold AMS does not let go for 2 seconds The unit will automatically search or press the up and down button to perform a channel search. Can't solve the above 2 points, Please unplug the antenna plug and find a screwdriver or a metal strip to insert it instead of the antenna.

12> Just installed no sound

--- Dear customers, the unit has been tested before shipment. If there is no sound, it is usually a wiring error or the original car speaker wire is short-circuited with iron. Please do not doubt the unit. According to the steps to check it.

1. Check if the speaker cable is short-circuited and connected. Please reconnect if you have any short circuit.
2. Check how many speaker cables according to the original speaker cable if there are only 2 speaker cables to prove that the original car line does not match our unit, you need to re-route the original car line. One speaker must lead to 2 speaker wires. 2 speakers must be have 4 speaker cables to available.

13> After a while there is no sound

--- Disconnect all the speaker cable from the unit (do not remove all of them), and then find an external speaker to receive the gray and purple of the tail line of the unit. Green any group, and then try to see if there is any sound. If there is a sound, it is proved that the car's speaker line is short-circuited with iron or the speaker is damaged. If there is no sound, the unit is broken.

MANUAL DE FUNCIONAMIENTO

**REPRODUCTOR MP5 PARA
AUTOMÓVIL CON PANEL DE
PANTALLA HD DE 7 PULGADAS
RECEPTOR DE RADIO FM
BT MIRRORLINK**

Antes de la instalación

Muchas gracias por comprar y utilizar nuestros productos, cuando reciba el producto, por favor, no lleve el producto inmediatamente al automóvil para su instalación, ya que el producto ha recorrido un largo viaje el cual pudo haber afectado al producto. Por favor, pruebe el aparato antes de instalarlo.

Método de prueba: Lleve el aparato a la batería del automóvil y pruébelo. Este estereo de automóvil se aplica a una fuente de alimentación a 12V DC. Conecte los cables rojo y amarillo del cable de alimentación del aparato y conéctelo al polo positivo de la batería.

El alambre negro del cable de alimentación se conecta al polo negativo de la batería. Espere 10 segundos tras la conexión y pulse cada botón del aparato para ver si el aparato puede arrancar normalmente. Si se puede encender, significa que no hay problema, puede instalarlo. Si el aparato de prueba no puede arrancar normalmente, por favor una vez más confirme que sigue los pasos de nuestro método de prueba en estricta conformidad con la funcionamiento. Si el problema aún no se resuelve, póngase en contacto con nuestro trabajo oportunamente. Gracias por su cooperación.

PARÁMETROS BÁSICOS

Tensión de trabajo	DC12V
Corriente máxima	15 A
Temperatura de trabajo	-10 +60 °C
Tamaño de la pantalla	17.7 cm
Resolución de la pantalla	800x480
Sistema	Windows CE
Potencia de salida	60W x 4
Función BT	Versión:4.0 Micrófono incorporado
Conexión al Teléfono	Android/iPhone (Algunos teléfonos de alta versión no son compatibles)
Formato de vídeo compatible	RM/RMVB/FLV/3GP/MPEG/DIVX/DAT/VOB/AVI/MP4
Formato de audio compatible	MP3/WMA/WAV/FLAC/APE/OGG/
Formato de imagen compatible	JPG
Botón Ligero	Luz de colores automática /luz monocromática opcional
Radiofrecuencia	FM 87,5 ~ 108 MHz
Dispositivos multimedia compatibles	USB 2.0/tarjeta TF
Entrada Aux	Interfaz del panel frontal de 3,5 mm
Función de Giro Inverso	Compatibilidad (opción de cámara)
Control remoto	Control remoto por infrarrojos
Selección de idioma	Inglés/chino/España/Portugal/francés/Italia/Rusia/alemán/Turquía/checo/polaco/tailandés
controles en el volante,	Soporte Técnico

TAMAÑO DE LA INSTALACIÓN DE LA UNIDAD

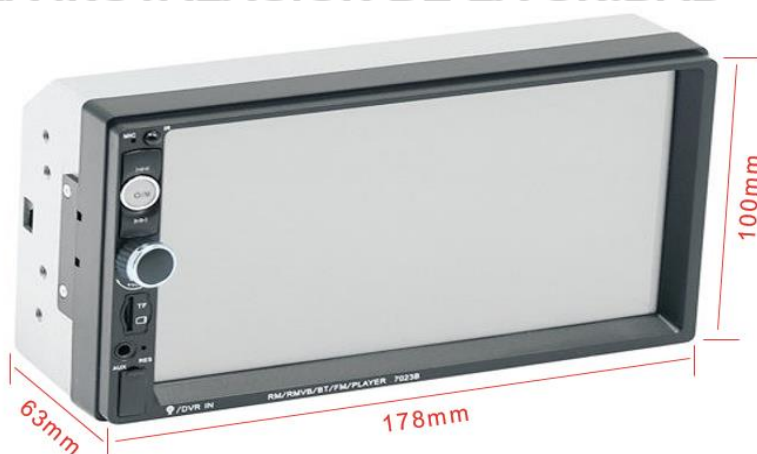

DESCRIPCIÓN DE LOS COMPONENTES DEL PANEL



DESCRIPCIÓN DE INTERFAZ TRASERA

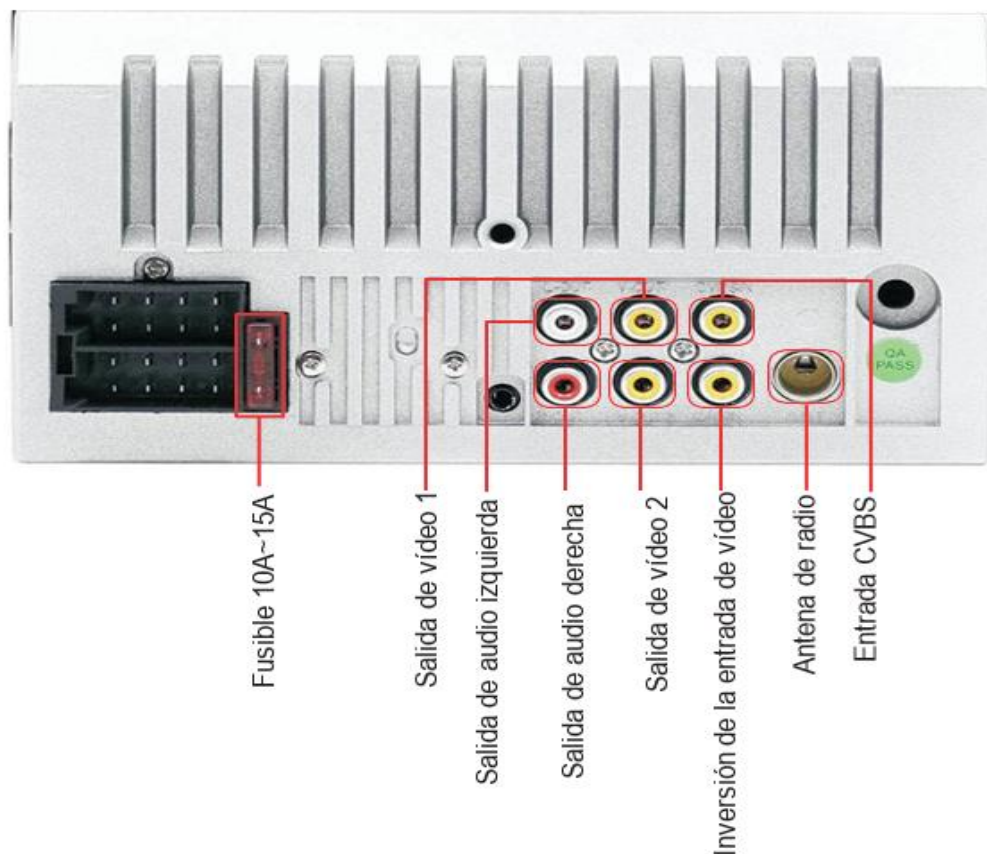

DESCRIPCIÓN DE LOS COMPONENTES DEL PANEL

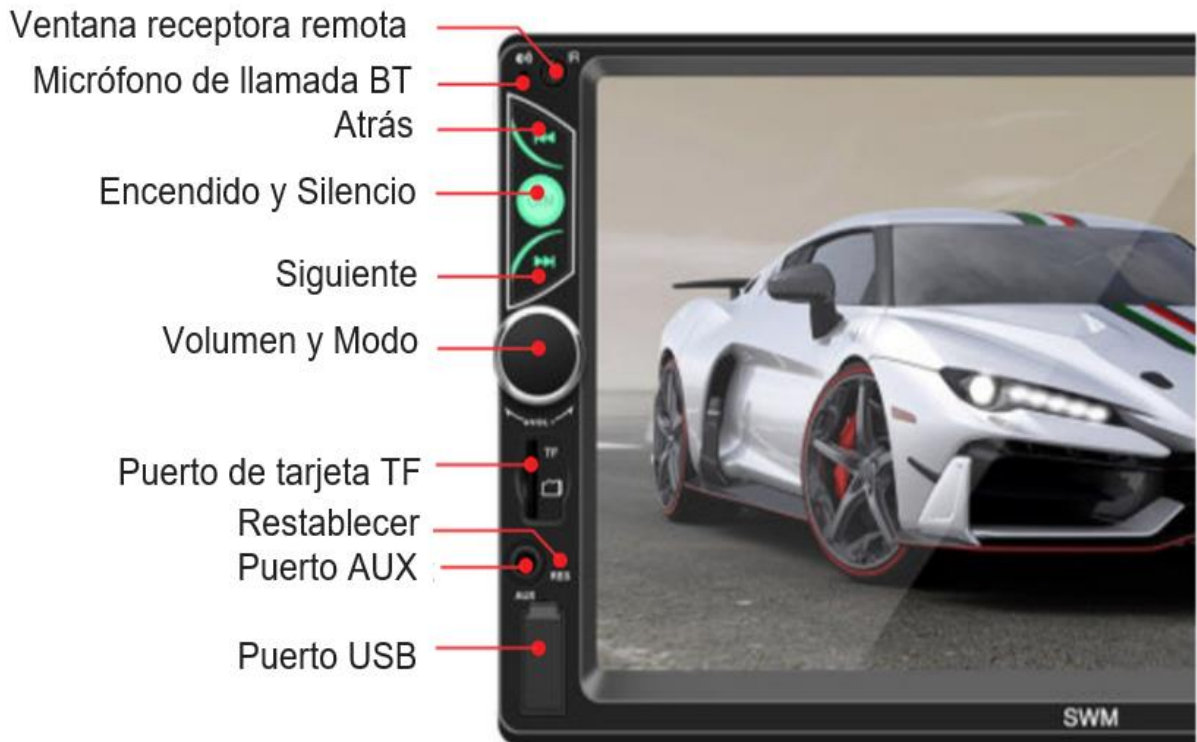

DESCRIPCIÓN DE INTERFAZ TRASERA

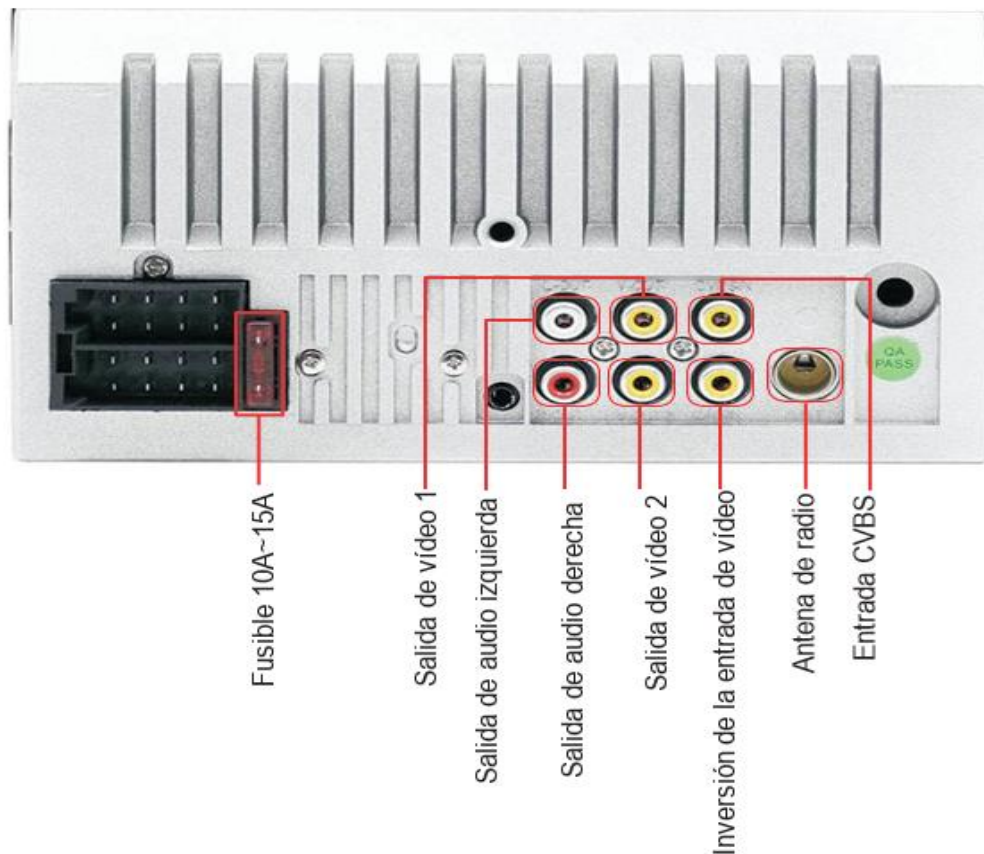

DESCRIPCIÓN DE INTERFAZ TRASERA

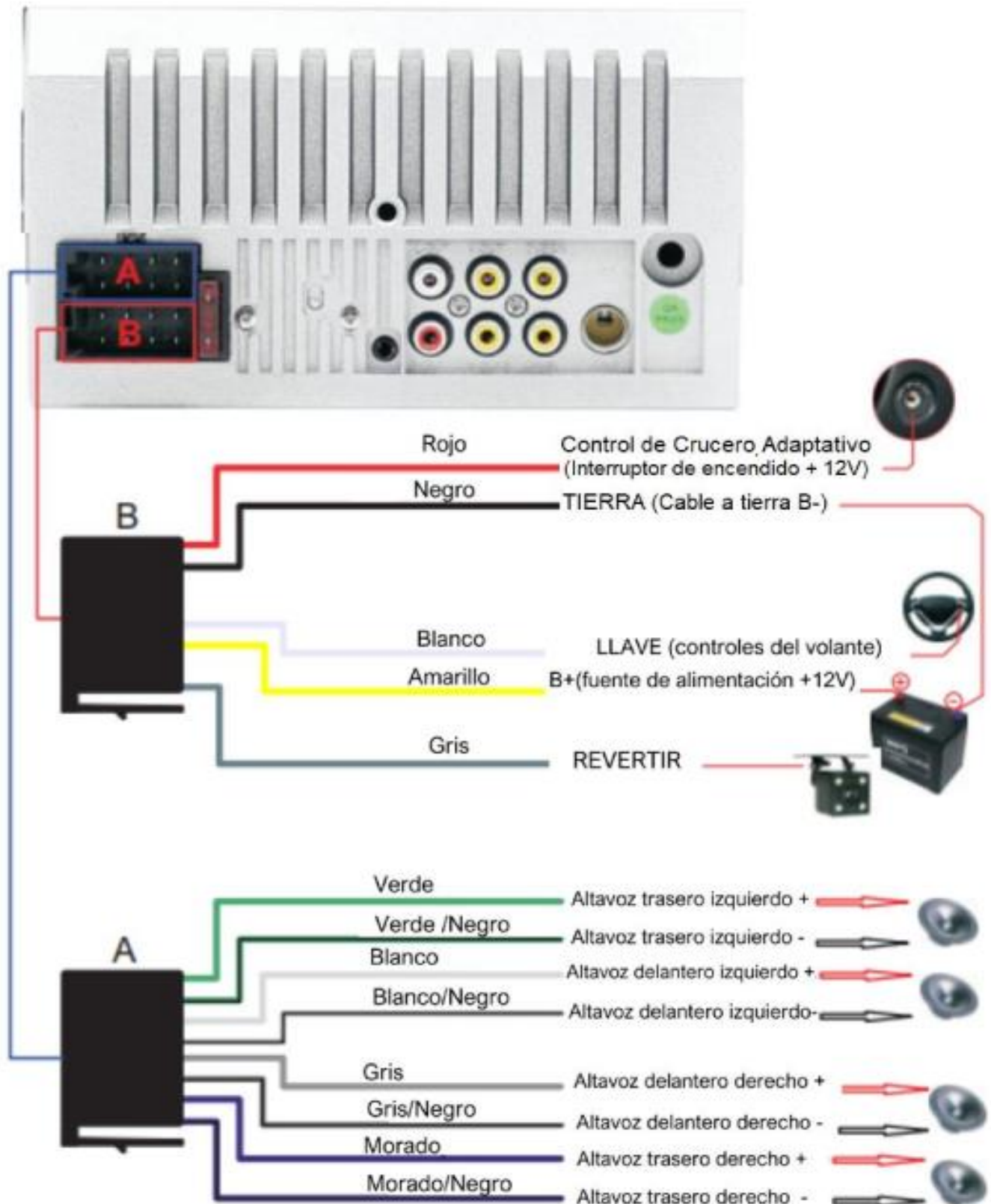

ENLACE DETELÉFONO PARA IPHONE

* Para iOS, la serie Xyversionessuperioresde teléfonosmóvilesno admiten el "enlace de teléfono móvil" con este aparato.

1. Conecte el aparato yel teléfono móvil con el cable de datosoriginal.
2. Cuando en el teléfono aparece un cuadro de diálogo: ¿Confiar en este equipo? Seleccione Aceptar para permitir el modo de interconexión.



CONTROLES DEL VOLANTE

1. Conecte el polo positivo del volante original a la línea blanca del enchufe de la máquina.
2. Conecte el polo negativo del cable del botón del volante del coche original al cable negro GND del enchufe de la máquina.
3. En la interfaz de "configuración", busque "Dirección" e ingrese.
4. Luego presione el botón para aprender. Después de que haya fijado el botón con éxito, haga clic en el botón "Aceptar" en la página. Después de guardar, puede utilizar los botones del volante original para controlar el estéreo.

Método de aprendizaje: presione y mantenga presionado un botón en el volante del automóvil original sin soltarlo, busque el ícono del botón correspondiente a la función del botón en el volante del vehículo. Haga clic en este icono para cambiar el color, lo que indica que el botón se ha activado con éxito, de la misma manera puede encender otros botones. Después de haber establecido todas las claves, haga clic en el botón "Aceptar" en la pantalla para guardar la configuración. Si necesita volver a fijar los botones, haga clic en el botón "RESTABLECER" en la pantalla y luego vuelva a fijarlos.



PROBLEMAS COMUNES Y SOLUCIONES SENCILLAS

1> No enciende con normalidad

— Motivos para no encender:

1. "Amarillo" "Rojo" "Negro" de estas tres líneas solo están conectadas dos de ellas, esto no permitirá un correcto funcionamiento, el cable amarillo debe estar conectado al polo positivo, el cable rojo a la línea de control de la llave, y el cable negro al polo negativo. Si no todos están conectados o se conectan de forma errónea, no encenderá.
2. Evite conectar la línea de coche original y el cableado de la unidad debido a que el color de la línea de coche original no es estándar, si se conectaran así, no solo se encenderá, sino que también puede arruinarse.
3. El enchufe original del coche no se puede conectar de manera directa en la nueva unidad, incluso si encaje a la perfección, no se puede utilizar, de lo contrario no encenderá o se quemará.
4. Los 3 cables están conectados en el orden correcto, pero no enciende. Compruebe si el fusible de la línea amarilla está dañado. Si no hay ningún problema con el fusible, intercambie los cables amarillo y rojo. Introduzca la llave y pulse el botón de encendido de la unidad para comprobar si enciende.
5. Cada vez que cambias el fusible, se quema. Por favor, no lo vuelva a cambiar ya que al conectar por primera vez los polos positivo y negativo, el circuito de protección de la unidad se cortocircuita. La unidad puede repararse bajo la supervisión del experto. No se puede devolver ninguna base sólo al departamento de posventa o la unidad nueva. Si este no es el problema, pero aún no funciona, realice el último paso para confirmar. Busque una batería de 12V o una fuente de alimentación de 12V, enrosque el cable " amarillo " y " rojo " en el polo positivo, y el negro en el polo negativo. Luego, presione el botón para verificar si funciona o no. Si está funcionando, quiere decir que la línea original del vehículo no está bien conectada, o que hay un problema con la línea del vehículo. Si no es posible arrancar, la unidad está rota. Si la unidad no funciona, revise la línea con cuidado, no suponga el problema de la unidad.

2> Apagado automático

— *El apagado automático generalmente tiene las siguientes condiciones*

1. Error de conexión del cable: Si el cable azul (fuente de alimentación automática de la antena) está conectado al cable de alimentación de la unidad, se producirá un apagado automático. Siga el método de cableado correcto para resolver el problema.
2. El voltaje es inestable: encuentre un 12V-5A que sea la fuente de alimentación y vuelva a probar para ver si se apaga automáticamente o no. Si no lo hace automáticamente apague después de la prueba, reemplace la fuente de alimentación. Si se apaga automáticamente, es un problema con la unidad.

3> Problemas de ruido

— *La situación general del ruido se debe a dos motivos*

1. La potencia del altavoz original es demasiado pequeña. Cuando suba el volumen de la unidad, habrá ruido.

Solución: Al reemplazar el altavoz o escuchar la canción, el volumen no debe ser demasiado alto.

2. El cable del altavoz está conectado a tierra.

Solución: Tome el cable de hierro del altavoz. Conectado directamente al cable del altavoz de la unidad.

4> La ajustes no se pueden guardar (sin memoria)

--- No hay función de memoria, solo hay 2 puntos en la memoria.

3. La línea amarilla y la línea roja están conectadas entre sí (separar amarillo a positivo, rojo a control clave).
4. Amarillo y rojo están invertidos (solo cambia de posición)

5> Audio del auto con BT, pero no funciona

--- Verifique el teléfono para ver si puede buscar el código de la unidad.

Pasos de la operación: encienda la unidad, use la búsqueda Bluetooth del teléfono para CAR-MP5, luego haga clic en la conexión, después de conectarse, puede contestar el teléfono o BT para reproducir la canción.

Código de PIN:0000

6> Humo en el producto demuestra que el circuito interno se ha quemado y cambiar el seguro del FUSIBLE no puede resolver el problema

--- En este caso, la unidad necesita ser reparada.

7> Cómo ajustar el sonido, dónde se ajusta el ecualizador, el sonido no se puede ajustar.

---Ajustar el sonido: gire el volumen para ajustar.

---Configuración del ecualizador: en general, presione la perilla de volumen para mostrar el SEL del ecualizador y gire la parte inferior del volumen para ajustar cada efecto de sonido.

---El sonido no se puede ajustar:

1. Reinicie la unidad o desconecte el cable de alimentación y conéctelo.
2. La perilla de volumen está rota y se puede reemplazar.

8> No admite ninguna imagen de la cámara de retroceso

---Por lo general, es debido a dos razones:

1. Se conectó incorrectamente o hace falta cableado. Para conectar la cámara siga los siguientes pasos:

a> Primero, busque los accesorios (una cámara + un cable de alimentación + un cable de video).

b> A continuación, busque el puerto del cableado. Primero encuentre la línea de control de inversión en la línea de alimentación de la unidad. La línea de control es una línea rosa o marrón, conéctela al polo positivo de 12V y la pantalla se volverá azul. En la parte trasera de la unidad, identifique la interfaz de entrada de vídeo CAME, así como el polo positivo y negativo de la luz de reversa. Para el siguiente paso conecte los cables: hay dos enchufes en la cámara, el enchufe rojo se conecta al cable de alimentación, el amarillo se inserta en el cable de vídeo, el hilo rojo del cable de alimentación y el hilo del cable de vídeo se enroscan juntos en el polo positivo de la luz de reversa, y el hilo negro del cable de alimentación no se utiliza, conectado, el otro extremo del cable de vídeo se conecta a la interfaz de entrada de vídeo

CAME de la interfaz de entrada en la parte posterior de la unidad. La línea roja que sale de la línea de vídeo está conectada a la línea de control de marcha trasera de la línea eléctrica.

2. La cámara está averiada. Si la lámpara que está correctamente conectada a la cámara no enciende, la cámara está averiada y debe reemplazarse por una nueva.

10> ¿la USB no reproduce sonido, no reconoce la tarjeta del mapa, el puerto USB de la tarjeta no entra en la ranura, la carpeta de la tarjeta del mapa no tiene contenido?

--- La USB no se puede reproducir:

Formatear La USB, y seleccionar el sistema de archivos como: FAT32, descargar una vez más una o dos canciones e inténtalo de nuevo. Si sigue sin funcionar, reemplace la unidad flas USB.

--- No se reconoce la tarjeta Mapa (solo para modelos GPS):

Inserte la tarjeta en el ordenador para formatear, descargue una vez más el mapa o cambie la tarjeta de memoria para instalar el software del mapa.

--- El puerto de la tarjeta no entra en la ranura:

Compruebe si la tarjeta de memoria está insertada, o si el enchufe está roto.

--- No muestra contenido en la carpeta de la tarjeta de mapa (solo para modelos GPS):
Inserte la tarjeta en el ordenador para visualizar. Si no hay contenido, tiene que descargarlo de nuevo.

11> FM no sintoniza las estaciones

--- No se puede recibir la estación compruebe los 2 puntos

El enchufe de la antena no está completamente insertado, la antena está desconectada o la línea está desconectada.

Canal de búsqueda, mantenga pulsado el botón AMS durante 2 segundos. La unidad buscará de forma automática, o pulse el botón arriba y abajo para realizar una búsqueda de canal. Si no puede resolver los 2 puntos anteriores, desconecte el cable de la antena y busque un destornillador o una tira de metal para insertarlo y sustituir la antena.

12> Acaba de instalar y no hay sonido

--- Estimados clientes, la unidad ha sido probada antes del envío. Si no hay sonido, generalmente es un error de cableado o el cable original que da al altavoz del vehículo está en cortocircuito con metal. Por favor, no dude del dispositivo. Sigue los pasos para comprobarlo.

Asegúrese que el cable del altavoz no está dañado y conectado. Por favor, vuelva a conectarlo si tiene algún corto circuito.

Compruebe cuántos cables de altavoz hay en función del cable original. Si sólo hay 2 cables para demostrar que la serie del vehículo no coincide con nuestra unidad, es necesario volver redireccionar la serie del vehículo. Un altavoz debe llevar 2 cables de altavoz. 2 altavoces deben tener 4 cables de altavoz disponibles.

13> Después de un tiempo no hay sonido

--- Desconecte todo el cable del altavoz del dispositivo (no desconecte todos los cables), y luego busque un altavoz externo para recibir el gris y el púrpura de la línea de cola de esta. El color verde en cualquier grupo, y luego tratar de ver si hay algún sonido. Si hay un sonido, se demuestra que la línea del altavoz del vehículo está en cortocircuito con metal o el altavoz está dañado. Si no hay sonido, la unidad está averiada.



GLOBAL - CONVERT TEXT

Agencia de traducción
Español - Inglés
Inglés- Español

(dirección)San salvador
Telf. 2234-4323
global.convert.text@gmail.com

GlobalConvertext.MuckUpWebSite.com

Project Manager:

Nubia Solano

Translators:

Cesar Alberto García Colindres
Rosibel Esmeralda LópezPérez
Milton Alexander Nieto Torres
Nubia Carolina Solano de Callejas

Proofreaders:

Cesar Alberto García Colindres
Rosibel Esmeralda LópezPérez
Milton Alexander Nieto Torres
Nubia Carolina Solano de Callejas

3.4 Birth certificates: Original

Folio 10 Libro 9o. "A"



PARTIDA NUMERO O C H O
NAYIB ARMANDO, sexo masculino nació a las dos horas, quin-
ce minutos del día veinticuatro de Julio del
pasado/ del día
año próximo/ en el hospital Centro Ginecológico;
es hijo de ARMANDO - BUKELE KATTAN y de OLGA MARINA-
ORTEZ el primero de treinta y siete
años de edad, doctor en química industrial/originario de esta ciudad
..... del domicilio de la misma
..... y de nacionalidad salvadoreña y la segunda, de veinti-
cuatro años de edad, estudiante originaria de
Concepción de Oriente, La Unión del domicilio de esta ciudad
..... y de nacionalidad salvadoreña Dio estos
datos ARMANDO - BUKELE KATTAN quien manifiesta ser
padre del inscrito Exhibió su Cédula de Identidad
Personal número uno- uno- ciento noventa y siete mil, quinientos
ochenta y ocho, expedida en esta ciudad
y firma
ALCALDIA MUNICIPAL, San Salvador, catorce de Julio
de mil novecientos ochenta y dos. Entre líneas-pasado-trial-Vale.

Informante

Jefe del Registro Civil

NAYIB ARMANDO BUKELE ORTEZ, contrajo matrimonio civil con GABRIELA ROBERTA RODRIGUEZ PEREZALONSO, el día seis de diciembre de dos mil catorce, ante CONAN TONATHIU CASTRO, NOTARIO, en SAN SALVADOR, los contrayentes optan por el Régimen Patrimonial SEPARACION DE BIENES, la contrayente usará los apellidos RODRIGUEZ DE BUKELE. Alcaldía Municipal: San Salvador, veintidós de diciembre de dos mil catorce.

LIC. JUAN JOSÉ ARMANDO AZUCENA CATÁN
JEFE DEL REGISTRO DEL ESTADO FAMILIAR



Translation

File Number: 10 book 9° "A"



CERTIFICATE NUMBER EIGHT.- - - - -

NAYIB ARMANDO, male - - - - - was born at two hours, fifteen minutes - - - - - of the twenty-fourth day last July, in Hospital Centro Ginecológico; - - - - - is the son of ARMANDO-BUKELE KATTAN - - - - - and OLGA MARINA ORTEZ - - - - - , the former of thirty-seven - - - - - years of age, industrial PHD in chemistry, native of this city - - - - - of the domicile of the same city- - - - - and Salvadoran nationality - - - - - , and the latter, of twenty-four - - - - - years of age, student, - - - - - , native of Concepción de Oriente, La Unión - - - - - , of the domicile of this city - - - - - and of Salvadoran nationality - - - - - . These data were given by ARMANDO-BUKELE KATTAN, - - - - - , who states to be the father of the registrant - - - - - . He provided his Personal Identity-Card number: one - one - one hundred ninety - seven thousand, five hundred eighty-eight, issued in this city- - - - - and signed. - - - - -

CITY HALL, San Salvador, July - - - - - fourteen - - - - - one thousand nine hundred and eighty-two. Between lines-past-trial-Valid.

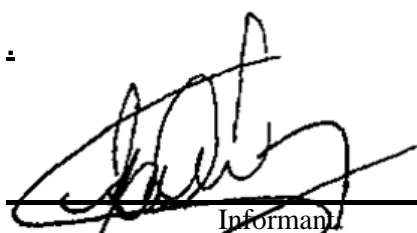
 Informant

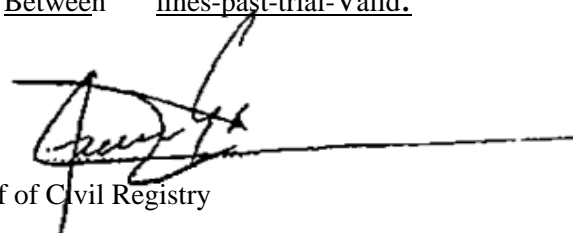
 Chief of Civil Registry

NAYIB ARMANDO BUKELE ORTEZ, was united in civil marriage with GABRIELA ROBERTA RODRIGUEZ PEREZALONSO, December sixth of two thousand fourteen, before CONAN TONATHIU CASTRO, NOTARY, in SAN SALVADOR, the contracting parties opt for the Matrimonial Property Regime SEPARATION OF ASSETS, and the undersigning party will use the surnames RODRÍGUEZ DE BUKELE. Local Mayor's Office: San Salvador, December twenty-second, two thousand and fourteen.

 LIC. JUAN JOSÉ ARMANDO AZUCENA CATÁN
 CHIEF OF FAMILY REGISTER



3.5 Marriage Certificates: *Original*

MODELO DE UN PARTIDA DE MATRIMONIO.

Partida Numero _____
nombre _____
de _____ años de edad,
estado civil _____
ocupación u oficio _____
originario de _____
del domicilio de _____
de nacionalidad _____
hijo de _____
y _____
de _____ años de edad,
estado civil _____
ocupación u oficio _____
originaria de _____
del domicilio de _____
de nacionalidad _____
hija de _____
y _____
contrajeron matrimonio civil, ante los oficios _____
a presencia de los testigos: _____
el día _____
régimen patrimonial _____
Alcaldía Municipal: _____ del dos mil _____

Jefe del Registro del Estado Familiar.

Translation

CERTIFICATE OF MARRIAGE

Certificate Number: 2986

Name: José Emanuel Hernández García,

Of: Twenty-eight years of age,

Marital Status: Single

Profession/Trade: Doctor in medicine

Native of: San Miguel

Of the Domicile of: Ciudad Barrios

Nationality: Salvadoran

Son of: Miguel Angel Hernández Gómez and

Amelia Johana García Pineda

And: Maria Magdalena Ruiz

Of: Twenty-five years of age,

Marital Status: Single

Profession/Trade: Waitress

Native of: San Salvador

Of the Domicile of: San Salvador

Nationality: Salvadoran

Daughter of: Marco Antonio Ruiz Fuentes and

Celia Eunice Hernández de Ruiz

Were joined in lawful wedlock, before Camila Molina,

NOTARY **by the authority of a license**

In the presence of witnesses Kevin Alexis Ortiz

Paiz and Delmy Elizabeth Hernández Sorto

On the seventeenth day of July of two thousand three

Matrimonial Property Regime of SEPARATION ASSETS

City Hall, San Salvador **of two thousand** three

3.6 University Transcripts: Original

UNIVERSIDAD DE EL SALVADOR

1998



1998

Nº 532021

CINCUENTA CENTAVOS

1	LA INFRASCrita SECRETARIO DE ASUNTOS ACADÉMICOS AD-HONOREM, DE LA UNIVERSIDAD			
2	DE EL SALVADOR, CERTIFICA QUE: [REDACTED], CURSO Y APROBADO			
3	EN ESTA UNIVERSIDAD DESDE EL AÑO ACADÉMICO 1986-1987, AL AÑO ACADÉMICO 1990-1991			
4	LAS ASIGNATURAS ABAJO DETALLADAS SIENDO ACTUALMENTE GRADUADA EN LA CARRERA DE			
5	LICENCIATURA EN QUÍMICA Y FARMACIA.-			
6	AÑO ACADÉMICO 1986-1987 CICLO I			
7	INGLES I	8.9	OCHO PUNTO NUEVE	APROBADA
8	QUÍMICA GENERAL I	8.8	OCHO PUNTO OCHO	APROBADA
9	FISICA I	9.1	NUEVE PUNTO UNO	APROBADA
10	MATEMÁTICA I	9.4	NUEVE PUNTO CUATRO	APROBADA
11	AÑO ACADÉMICO 1986-1987 CICLO II			
12	QUÍMICA GENERAL II	8.8	OCHO PUNTO OCHO	APROBADA
13	MATEMÁTICA II	9.7	NUEVE PUNTO SIETE	APROBADA
14	FISICA II	9.6	NUEVE PUNTO SEIS	APROBADA
15	INGLES II	8.0	OCHO PUNTO CERO	APROBADA
16	TECNICAS DE REDACCION E INVESTIGACION	9.2	NUEVE PUNTO DOS	APROBADA
17	AÑO ACADÉMICO 1987-1988 CICLO I			
18	MATEMÁTICA III	9.2	NUEVE PUNTO DOS	APROBADA
19	QUÍMICA INORGANICA I	7.8	SIETE PUNTO OCHO	APROBADA
20	QUÍMICA ORGANICA I	8.5	OCHO PUNTO CINCO	APROBADA
21	QUÍMICA ANALITICA I	8.1	OCHO PUNTO UNO	APROBADA
22	AÑO ACADÉMICO 1987-1988 CICLO II			
23	QUÍMICA ORGANICA II	6.5	SEIS PUNTO CINCO	APROBADA
24	QUÍMICA ANALITICA II	7.6	SIETE PUNTO SEIS	APROBADA

1	BIOLOGIA GENERAL	8.3	OCHO PUNTO TRES	APROBADA
2	ESTADISTICA	7.7	SIETE PUNTO SIETE	APROBADA
3	SOCIOLOGIA GENERAL	8.7	OCHO PUNTO SIETE	APROBADA
4	AÑO ACADEMICO 1988-1989 CICLO I			
5	QUIMICA ORGANICA III	7.5	SIETE PUNTO CINCO	APROBADA
6	PSICOLOGIA APLICADA A LA EMPRESA	9.3	NUEVE PUNTO TRES	APROBADA
7	QUIMICA FISICA I	6.7	SEIS PUNTO SIETE	APROBADA
8	BIOQUIMICA GENERAL	7.8	SIETE PUNTO OCHO	APROBADA
9	ZOOLOGIA GENERAL Y FARMACEUTICA	8.0	OCHO PUNTO CERO	APROBADA
10	AÑO ACADEMICO 1988-1989 CICLO II			
11	QUIMICA FISICA II	7.9	SIETE PUNTO NUEVE	APROBADA
12	ANATOMIA	8.6	OCHO PUNTO SEIS	APROBADA
13	MICROBIOLOGIA Y PARASITOLOGIA	8.5	OCHO PUNTO CINCO	APROBADA
14	BOTANICA GENERAL Y FARMACEUTICA	8.5	OCHO PUNTO CINCO	APROBADA
15	PRINCIPIOS DE ADMINISTRACION	7.6	SIETE PUNTO SEIS	APROBADA
16	AÑO ACADEMICO 1989-1990 CICLO I			
17	FARMACOQUIMICA	7.8	SIETE PUNTO OCHO	APROBADA
18	FISIOLOGIA	8.4	OCHO PUNTO CUATRO	APROBADA
19	FARMACOGNOSIA	8.0	OCHO PUNTO CERO	APROBADA
20	QUIMICA ANALITICA III	8.7	OCHO PUNTO SIETE	APROBADA
21	QUIMICA AGRICOLA APLICADA I	8.6	OCHO PUNTO SEIS	APROBADA
22	AÑO ACADEMICO 1989-1990 CICLO II			
23	ANALISIS BROMATOLOGICO	8.3	OCHO PUNTO TRES	APROBADA
24	FARMACOTECNIA	8.7	OCHO PUNTO SIETE	APROBADA

PASA A LA HOJA No. 192121



CINCUENTA CENTAVOS

1	FARMACOLOGIA	9.0	NUEVE PUNTO CERO	APROBADA
2	QUIMICA AGRICOLA APLICADA II	9.6	NUEVE PUNTO SEIS	APROBADA
3	AÑO ACADÉMICO 1990-1991 CICLO I			
4	CONTROL DE CALIDAD DE PRODUCTOS FARMA-			
5	CEUTICOS HUMANOS Y VETERINARIOS I	8.1	OCHO PUNTO UNO	APROBADA
6	TECNOLOGIA FARMACEUTICA I	8.6	OCHO PUNTO SEIS	APROBADA
7	QUIMICA LEGAL Y ANALISIS TOXICOLOGICO	8.3	OCHO PUNTO TRES	APROBADA
8	CONTAMINACION AMBIENTAL Y SALUD PUBLICA	7.7	SIETE PUNTO SIETE	APROBADA
9	QUIMICA AGRICOLA APLICADA III	9.1	NUEVE PUNTO UNO	APROBADA
10	AÑO ACADÉMICO 1990-1991 CICLO II			
11	CONTROL DE CALIDAD DE PRODUCTOS FARMA-			
12	CEUTICOS HUMANOS Y VETERINARIOS II	9.1	NUEVE PUNTO UNO	APROBADA
13	TECNOLOGIA FARMACEUTICA II	8.4	OCHO PUNTO CUATRO	APROBADA
14	LEGISLACION FARMACEUTICA DEONTOLOGIA	8.8	OCHO PUNTO OCHO	APROBADA
15	QUIMICA INDUSTRIAL E INVESTIGACION Y APRO-			
16	VECHAMIENTO DE RECURSOS NATURALES	8.1	OCHO PUNTO UNO	APROBADA
17	QUIMICA AGRICOLA APLICADA IV	9.1	NUEVE PUNTO UNO	APROBADA
18	LA ESCALA DE CALIFICACION ES DE CERO PUNTO CERO (0.0) A DIEZ PUNTO CERO (10.0)			
19	NOTA MINIMA DE APROBACION ES DE SEIS PUNTO CERO (6.0) ESTA CERTIFICACION AMPARA			
20	CUARENTA Y SIETE (47) ASIGNATURAS APROBADAS. Y, PARA LOS USOS QUE CONVENGAN A LA			
21	INTERESADA, SE LE EXTIENDE, FIRMA Y SELLA LA PRESENTE CERTIFICACION GLOBAL DE -			
22	NOTAS, EN LA CIUDAD UNIVERSITARIA, SAN SALVADOR, A LOS DOS DIAS DEL MES DE JULIO			
23	DE MIL NOVECIENTOS NOVENTA Y OCHO.-----			
24	-----			

1
2
3
4
5
6
7
8
9
10
11
12
13
14
15
16
17
18
19
20
21
22
23
24

Adela Muñoz Chávez de Melgar



LICDA. ADELA MUÑOZ CHAVEZ DE MELGAR

SECRETARIO DE ASUNTOS ACADEMICOS AD-HONOREM.

ELABORO : MIRNA CORADO

CONFRONTO: MELANI RIVAS

RECIBO No. 518744

[Handwritten signature]

El Infrascrito Secretario General de la Universidad de El Salvador

CERTIFICA QUE: La firma que aparece al pie de la anterior Certificación

GLOBALE DE NOTAS extendida a [redacted], es

autentica por haber sido puesta por la LIC. ADELA MUÑOZ CHAVEZ DE MELGAR,

Secretario de Asuntos Académicos Ad-Honorem de esta Universidad.

Dicho documento está elaborado en dos hoja (s) de papel esp. 532021/ 192121;

firmado y sellado por el suscrito Secretario General de la Universidad de

El Salvador.

San Salvador, a los once días del mes de noviembre de mil

novecientos noventa y ocho.

[Handwritten signature]

ENNIO ARIUNO LUNA

SECRETARIO GENERAL

R.T. 863145

JMG.

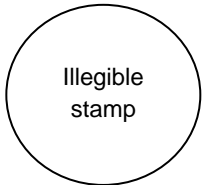

UNIVERSIDAD DE EL SALVADOR

1998



1998

N° 532021

FIFTY CENTS

1 THE UNDERSIGNED SECRETARY OF ACADEMIC AFFAIRS AD-HONOREM, OF UNIVERSIDAD

2 DE EL SALVADOR, CERTIFIES THAT: [REDACTED], STUDIED AND PASSED

3 IN THIS UNIVERSITY FROM THE ACADEMIC YEAR 1986-1987, TO THE ACADEMIC YEAR 1990-1991

4 THE SUBJECTS DETAILED BELOW, BEING CURRENTLY GRADUATED IN THE CAREER OF

5 **BACHELOR IN CHEMISTRY AND PHARMACY.—**

6 ACADEMIC YEAR 1986-1987 SEMESTER I

7 ENGLISH I 8.9 EIGHT POINT NINE APPROVED

8 GENERAL CHEMISTRY I 8.8 EIGHT POINT EIGHT APPROVED

9 PHYSICS I 9.1 NINE POINT ONE APPROVED

10 MATHEMATICS I 9.4 NINE POINT FOUR APPROVED

11 ACADEMIC YEAR 1986-1987 SEMESTER II

12 GENERAL CHEMISTRY II 8.8 EIGHT POINT EIGHT APPROVED

13 MATHEMATICS II 9.7 NINE POINT SEVEN APPROVED

14 PHYSICS II 9.6 NINE POINT SIX APPROVED

15 ENGLISH II 8.0 EIGHT POINT ZERO APPROVED

16 WRITING AND RESEARCH TECHNIQUES 9.2 NINE POINT TWO APPROVED

17 ACADEMIC YEAR 1987-1988 SEMESTER I

18 MATHEMATICS III 9.2 NINE POINT TWO APPROVED

19 INORGANIC CHEMISTRY I 7.8 SEVEN POINT EIGHT APPROVED

20 ORGANIC CHEMISTRY I 8.5 EIGHT POINT FIVE APPROVED

21 ANALYTICAL CHEMISTRY I 8.1 EIGHT POINT ONE APPROVED

22 ACADEMIC YEAR 1987-1988 SEMESTER II

23 ORGANIC CHEMISTRY II 6.5 SIX POINT FIVE APPROVED

24 ANALYTICAL CHEMISTRY II 7.6 SEVEN POINT SIX APPROVED

1	GENERAL BIOLOGY	8.3	EIGHT POINT THREE	APPROVED
2	STATISTICS	7.7	SEVEN POINT SEVEN	APPROVED
3	GENERAL SOCIOLOGY	8.7	EIGHT POINT SEVEN	APPROVED
4	ACADEMIC YEAR 1988-1989 SEMESTER I			
5	ORGANIC CHEMISTRY III	7.5	SEVEN POINT FIVE	APPROVED
6	BUSINESS PSYCHOLOGY	9.3	NINE POINT THREE	APPROVED
7	PHYSICAL CHEMISTRY I	6.7	SIX POINT SEVEN	APPROVED
8	GENERAL BIOCHEMISTRY	7.8	SEVEN POINT EIGHT	APPROVED
9	GENERAL AND PHARMACEUTICAL ZOOLOGY	8.0	EIGHT POINT ZERO	APPROVED
10	ACADEMIC YEAR 1988-1989 SEMESTER II			
11	PHYSICAL CHEMISTRY II	7.9	SEVEN POINT NINE	APPROVED
12	ANATOMY	8.6	EIGHT POINT SIX	APPROVED
13	MICROBIOLOGY AND PARASITOLOGY	8.5	EIGHT POINT FIVE	APPROVED
14	GENERAL AND PHARMACEUTICAL BOTANY	8.5	EIGHT POINT FIVE	APPROVED
15	PRINCIPLE OF BUSINESS ADMINISTRATION	7.6	SEVEN POINT SIX	APPROVED
16	ACADEMIC YEAR 1989-1990 SEMESTER I			
17	PHARMACOCHEMISTRY	7.8	SEVEN POINT EIGHT	APPROVED
18	PHYSIOLOGY	8.4	EIGHT POINT FOUR	APPROVED
19	PHARMACOGNOSY	8.0	EIGHT POINT ZERO	APPROVED
20	ANALYTICAL CHEMISTRY III	8.7	EIGHT POINT SEVEN	APPROVED
21	APPLIED AGRICULTURAL CHEMISTRY	8.0	EIGHT POINT ZERO	APPROVED
22	ACADEMIC YEAR 1989-1990 SEMESTER II			
23	BROMATOLOGICAL ANALYSIS	8.3	EIGHT POINT THREE	APPROVED
24	PHARMACOLOGY	8.7	EIGHT POINT SEVEN	APPROVED

GO TO THE PAGE No. 212119.

Illegible stamp

UNIVERSIDAD DE EL SALVADOR

1998



1998

N° 192121

FIFTY CENTS

1	PHARMACOLOGY	9.0	NINE POINT ZERO	APPROVED
2	AGRICULTURAL CHEMISTRY APPLIED II	9.6	NINE POINT SIX	APPROVED
3	ACADEMIC YEAR 1990-1991 SEMESTER I			
4	QUALITY CONTROL OF HUMAN AND			
5	VETERINARY PHARMACEUTICAL PRODUCTS I	8.1	EIGHT POINT ONE	APPROVED
6	PHARMACEUTICAL TECHNOLOGY I	8.6	EIGHT POINT SIX	APPROVED
7	FORENSIC CHEMISTRY AND TOXICOLOGICAL ANALYSIS	8.3	EIGHT POINT THREE	APPROVED
8	ENVIRONMENTAL POLLUTION AND PUBLIC HEALTH	7.7	SEVEN POINT SEVEN	APPROVED
9	AGRICULTURAL CHEMISTRY APPLIED III	9.1	NINE POINT ONE	APPROVED
10	ACADEMIC YEAR 1990-1991 SEMESTER II			
11	QUALITY CONTROL OF HUMAN AND			
12	VETERINARY PHARMACEUTICAL PRODUCTS II	9.1	NINE POINT ONE	APPROVED
13	PHARMACEUTICAL TECHNOLOGY II	8.4	EIGHT POINT FOUR	APPROVED
14	LEGISLATION PHARMACEUTICAL DEONTOLOGY	8.8	EIGHT POINT EIGHT	APPROVED
15	INDUSTRIAL CHEMISTRY AND RESEARCH AND			
16	EXPLOITATION OF NATURAL RESOURCES	8.1	EIGHT POINT ONE	APPROVED
17	APPLIED AGRICULTURA CHEMISTRY III	9.1	NINE POINT ONE	APPROVED
18	THE GRADE SCALE IS FROM ZERO POINT ZERO (0. 0) TO TEN POINT ZERO (10.0)			
19	THE MINIMUM PASSING GRADE IS SIX POINT ZERO (6. 0) THIS CERTIFICATION COVERS			
20	FORTY-SEVEN (47) PASSED SUBJECTS. AND, FOR USES THAT ARE CONVENIENT TO THE			
21	INTERESTED PARTY, THE PRESENT TRANSCRIPT OF GLOBAL GRADES ARE EXTENDED, SIGNED, AND			
22	STAMPED, IN THE UNIVERSITY CITY, SAN SALVADOR, ON THE SECOND DAY OF THE MONTH OF JULY			
23	OF ONE THOUSAND NINE HUNDRED NINETY-EIGHT. -----			
24	-----			

1 (Signature) (stamp)

2 LICDA. ADELA MUÑOZ CHAVEZ DE MELGAR

3 SECRETARY OF ACADEMIC AFFAIRS AD-HONOREM.

4 ISSUED BY: MIRNA CORADO (signature)

5 CONFRONTED: MELANI RIVAS (signature)

6 RECEIPT No. 518744

7 (Signature)

8

9 The undersigned Secretary General of Universidad de El Salvador

10 CERTIFIES THAT: The signature that appears at the bottom of the above Certification

11 GLOBAL NOTES issued to [REDACTED], is

12 authentic for having been affixed by LIC. ADELA MUNOZ CHAVEZ DE MELGAR,

13 Ad-Honorem Secretary of Academic Affairs of this university.

14 Said document is prepared on two sheet(s) of esp. paper 532021/ 192121;

15 signed and stamped by the undersigned Secretary-General of the University of

16 El Salvador.

17 San Salvador, on the eleventh day of the month of November of the year one thousand

18 ninety-nine hundred ninety-eight

19 (Signature)

20 ENNIO ARTURO LUNA

21 SECRETARY-GENERAL

22 (illegible) 863145

23 (illegible)

24

3.7 University / High school Diplomas: Original

North Stanly High School

Stanly County



North Carolina

This Certifies That

Tommy Allen Thompson

Has satisfactorily completed a Course of Study prescribed for Graduation
from this School and is therefore awarded this

Diploma

Given in the month of June, Nineteen hundred and eighty-six

Superintendent

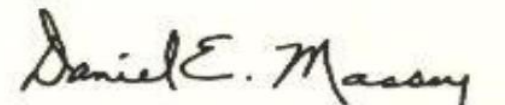
Principal

Translation

North Stanly High School

Stanly County



North Carolina

El presente documento certifica que
Tommy Allen Thompson

Ha completado satisfactoriamente un plan de estudios requerido para la graduación de esta institución y, por lo tanto, se le extiende el presente

Diploma

otorgado en junio de mil novecientos ochenta y seis

Superintendente

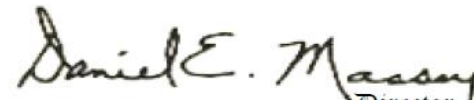
Director

3.8 Medical Certificate: Original

El suscrito médico general Rodolfo Lagos Calles legalmente autorizado para ejercer la profesión de médico cirujano, con cédula profesional 78965-8324

Certifica

Que habiendo practicado un reconocimiento médico el día dos de agosto del dos mil ocho a las nueve horas, a Patricia Espinoza Tieso, de dieciocho años de edad, la encontré: en perfecto estado de salud física y mental, sin signos agudos ni crónicos que revelen consumo de algún tipo de droga, estupefaciente o psicotrópico. El examen de orina fue evaluado en el laboratorio y tuvo un resultado negativo ante la presencia de restos de cualquier tipo de droga.

Por lo anterior se hace constar que Patricia Espinoza Tieso, no presenta evidencia de consumo de drogas, estupefacientes o psicotrópicos.

El presente certificado médico es expedido a petición de la interesada, Patricia Espinoza Tieso, para lo que a ella convenga a los treinta días del mes de agosto del dos mil ocho.

Dr. Rodolfo Calles Lagos

Ced. Prof: 78965-8324

Fuente: https://www.ejemplode.com/64-cartas/1750-ejemplo_de_constancia_medica.html#ixzz8FJHQcosn

Translation

The undersigned general practitioner Rodolfo Lagos Calles legally authorized to practice the profession of doctor-surgeon, with medical license number 78965-8324

Certifies the following:

Having performed a medical examination on the second day of August, two thousand and eight at nine o'clock in the morning, Patricia Espinoza Tieso, eighteen years old, was found to be in perfect physical and mental health, with no acute or chronic signs of drug, narcotic, or psychotropic use. The urine test was evaluated in the laboratory and was negative for the presence of any drug residues.

Therefore, it is hereby stated that Patricia Espinoza Tieso does not present evidence of drug, narcotic, or psychotropic consumption.

This medical certificate is issued on the thirtieth day of August, two thousand eight at the request of the interested party, Patricia Espinoza Tieso, for the uses she deems convenient.

MD. Rodolfo Calles Lagos
License No.: 78965-8324

Source: https://www.ejemplode.com/64-cartas/1750-ejemplo_de_constancia_medica.html#ixzz8FJHQcosn

4. CONCLUSIONS

4.1 Argumentative essay on translation practices

After having put into practice what we have learned during the course with the exercises and translation work, we can conclude that, it is important to understand that being a translator is quite a complex job, that requires skills and knowledge of techniques, apart from making good use of the technological tools that contribute to making a good translation.

The application of the translation techniques allowed us to make a better translation, to give it meaning and to adapt some of them to our language with precision since it is not always correct to do a literal translation, which is to translate word to word in such a way that in several of the documents worked an oblique translation was made, which consists of the application of translation techniques, added to this, apply the grammatical rules correctly.

An important part during this course was to create the translation process in which we write the steps to follow when doing a translation, and this allowed us as a group to have a better organization when translating the texts or documents assigned to the classes, having efficient results when finishing the translations.

The translation tools (CAT TOOLS) used has also been an important part for us as beginner translators, which, at first, we made it difficult to use some of them, but then with practice made it easier for us to translate some documents, without forgetting to mention, that this does not mean that a machine will do all the translation for us, that's where we apply the translation techniques and skills of each member of the group to have a quality translation.

However, the use of CAT Tools in the translation process ultimately speeds up the translation process and therefore generates more suitable jobs.

At the time of translating, we are faced with different types of texts or documents including images, with which we realized what, research before doing a translation is part of a translator's job as we may come across subjects with which we are not familiar e.g. health, finance, technology, mechanics etc., taking into account that, in the future, as translators we can specialize in a specific area to work with. Handling the jargon of each technical field opens up a number of specific connotations for each field.

CAT Tools also gave us the advantage of having glossaries and specific memory about each jargon used according to the type of text of each of the translations we made. Computer-assisted translation tools proved to be efficient even on topics such as literary a bit controversial for the use of CAT Tools, as recorded by The Routledge Handbook of Translation- since this type of text tends to carry connotations less technical and more related to literary figures which tend to carry more figurative senses.

5. RECOMMENDATIONS

- Recommendations for students.
 - ✓ Students should study well and consider the steps, processes, and or techniques they have to apply and those they have to avoid.
 - ✓ Students should do a previous research of the document they are going to translate, especially when they are not familiar with the terms of the original document.
 - ✓ Students should be become detail-oriented when translating.
 - ✓ Students should avoid copying and pasting a translation into a document from a CAT tool as a final translation; instead, students must check first its coherence and meaning.

- Recommendations during the course.
 - ✓ Allow students to take the necessary time to understand and properly use the functions offered by the Cat Tools in order to take advantage of their potential.
 - ✓ Encourage them to become familiar with the Cat Tools glossaries and learn how to create and save their own glossary.

6.0 REFERENCES

- Alotaibi, Hind. (2014). Alotaibi, H. M "Teaching CAT Tools to Translation Students: an Examination of Their Expectations and Attitudes.", AWEJ. Special Issue on Translation No.3 May, 2014, Pp. 65 - 74.. AWEJ. 65-74.
- Crystal D. (1991). The Cambridge encyclopedia of language. Cambridge, UK: Cambridge University Press. Retrieved from https://scholar.google.com/scholar_lookup?title=The+Cambridge+encyclopedia+of+language.&author=D.+Crystal&publication_year=1991
- Deane-Cox, S., & Spiessens, A. (2022). The Routledge Handbook of Translation and Memory. Routledge is an imprint of the Taylor & Francis Group, an informa business.
- George Steiner's After Babel in contemporary Translation Studies. After Babel: Aspects of Language and Translation, by George Steiner <https://doi.org/10.1080/23753234.2019.1664922>
- Grossman, Edith. Why Translation Matters, New Haven: Yale University Press. [Google Scholar] <https://doi.org/10.1080/07374836.2012.703119>
- Kornacki, M. (2018). Computer-assisted translation (CAT) tools in the translator training process. Berlin: Peter Lang.

- Rainer Schulte (2012) What Is Translation?, *Translation Review*, 83:1, 1-4, DOI: 10.1080/07374836.2012.703119
- Skripak, I. A., Shatskaya, A. V., Ukhanova, E. V., Tkachenko, A. E., & Simonova, N. A. (2022). Information Technologies and language: The impact of CAT systems on improving the efficiency of translators' training. *Theory and Practice in Language Studies*, 12(11), 23582364. <https://doi.org/10.17507/tpls.1211.16>